

COMPONENTS SUBSTRUCTURAL

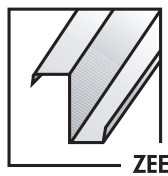

ZEE

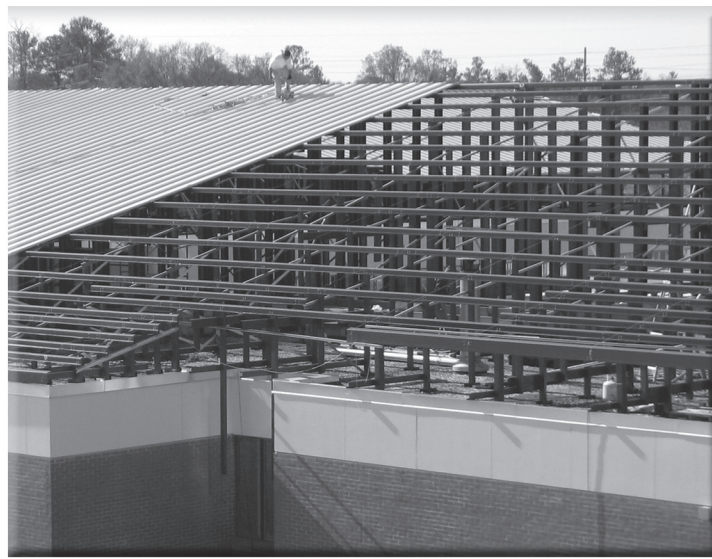

CEE



EAVE STRUT



SUB-GIRT



HAT



CHANNEL



MAC-GIRT

Product Information



McELROY METAL

McElroy Metal manufactures a complete line of cold-formed substructural components including Cees, Zees, Eave Struts, Sub-Girts, Angles, Hats, and Channels. Purlins and girts are manufactured in popular gauges and in a variety of section depths and flange widths. Red oxide is standard for all components. Galvanized (G-90) is also available. Galvanized is standard finish in Adelanto, California. This wide range of availability offers unlimited design flexibility in a quality product. Cees, Zees and Eave Struts are punched according to universal punching patterns, or custom punching is available.

STANDARD PUNCHING PATTERNS CEES AND ZEES

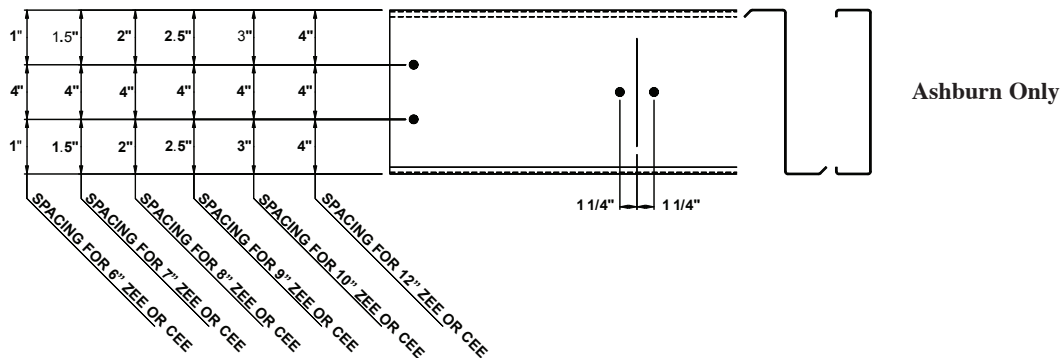
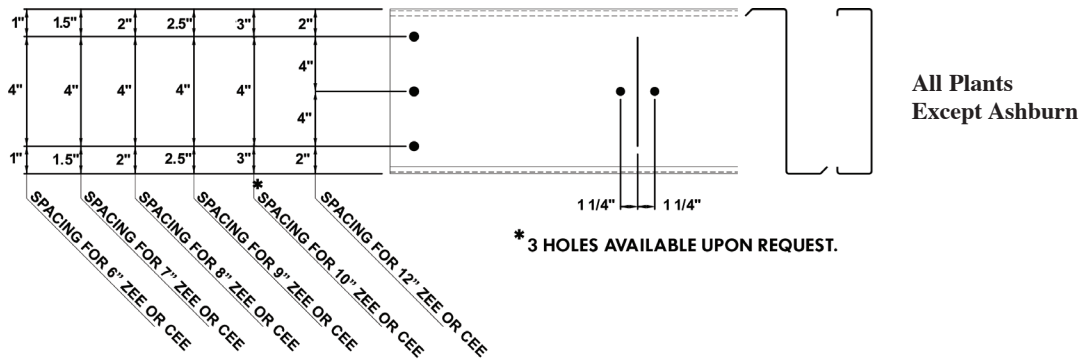

Available Flange Widths For Symmetrical Zees & All Cee

AVAILABLE FLANGE WIDTHS
FOR ZEES (6" THRU 12")

SECTION FLANGE	ACTUAL DIM. (ZEES)
2 1/2	2 1/8 & 2 3/8
3	2 5/8 & 2 7/8
3 1/2	3 1/8 & 3 3/8

NOTE:
HOLES WILL ALWAYS
BE PUNCHED IN WIDER FLANGE.

2 1/2" / 3" or 3 1/2"
NOMINAL FLANGE
WIDTHS FOR
6" THRU 12" ZEES

2 1/2" / 3 1/2" or 4"
FLANGE WIDTHS
FOR
6" THRU 12" CEES

1 3/4" SEE NOTE #3.

1 3/4" SEE NOTE #3.
ONE (1) FLANGE ONLY

1 3/4" SEE NOTE #3.
ONE (1) FLANGE ONLY

GENERAL NOTES

- All Cees are manufactured with symmetrical flanges.
- For code requirements, contact McElroy's Engineering Department.
- Flange punching is available on 6" through 12" Zees and Cees, but must be requested.
- Web punching is available on 6" through 12" Zees and Cees. For web punching on 4" members, contact McElroy's Customer Service Department or Sales Representative.
- Limited web and flange holes may be added. A drawing must accompany the order.
- Zeas and Cees may have extra holes - these are used for alternate bolting patterns.
- Sag rod holes, when requested, are located at the center of the Cee or Zee length, and at the center of the section depth. A drawing must accompany orders for other hole locations.
- For lengths less than 8' that require punching, contact McElroy's Customer Service Department.
- Round holes are 5/8" diameter, slots are 5/8" x 3/4".
- Holes are punched to accommodate 1/2" diameter bolts.
- Center hole all plant except Ashburn.

STANDARD PUNCHING PATTERNS ORDER INFORMATION EAVE STRUTS

SIZE	GAUGE
10"	14
8"	14
7"	14

Other section depths compatible with cees and zees are available. Contact Customer Service for more information.

Note: Available in punched or unpunched.

ORDER INFORMATION

To determine actual order length, subtract 1/2" from bay spacing.

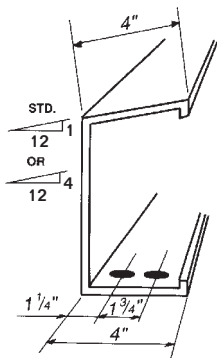
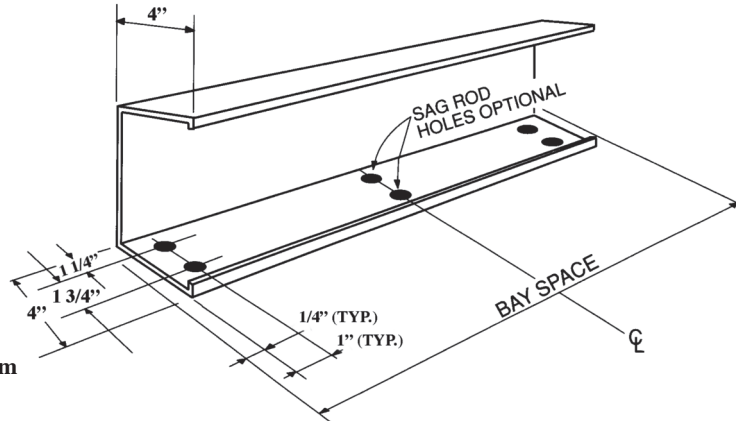

STANDARD
Single Slope Low

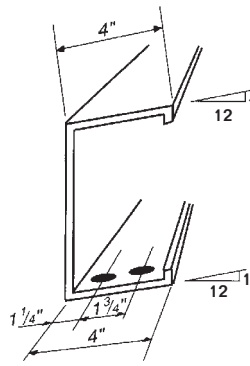

DOUBLE SLOPE LOW

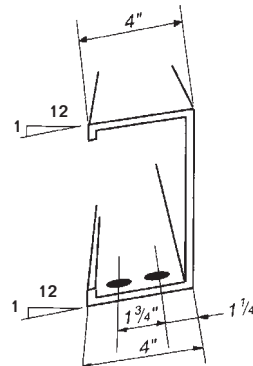

DOUBLE SLOPE HIGH

Note: Double slope eave struts are available in the same sizes and gauges as standard eave struts. When ordering, please request double slope.

* 5" Flange also available in Bossier City, Clinton, Adelanto, and Ashburn.

Substructural Angles and Channels

Note: Substructural Angles and Channels are available in 12, 14, and 16 gauge.

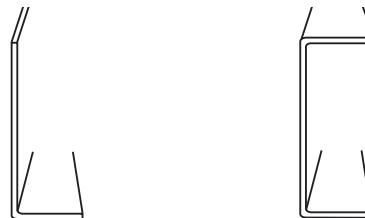

IMPORTANT INFORMATION

- Standard structural shapes are available in 16, 14 and 12 gauge, hi-strength hot rolled material as per ASTM A1011 Grade 55 Steel.
- Section properties have been calculated in accordance with the 2007 edition of AISI specifications.
- Standard finish is red oxide primer. Galvanized (G-90) as per ASTM A653 is also available. Contact Customer Service for lead times. (Note: Galvanized is standard finish in Adelanto, CA.)
- Please inquire concerning special custom shaped sections and special punching.
- Engineering data available at: www.mcelroymetal.com.

STANDARD PUNCHING PATTERNS ORDER INFORMATION CEES AND ZEES

SIMPLE SPAN

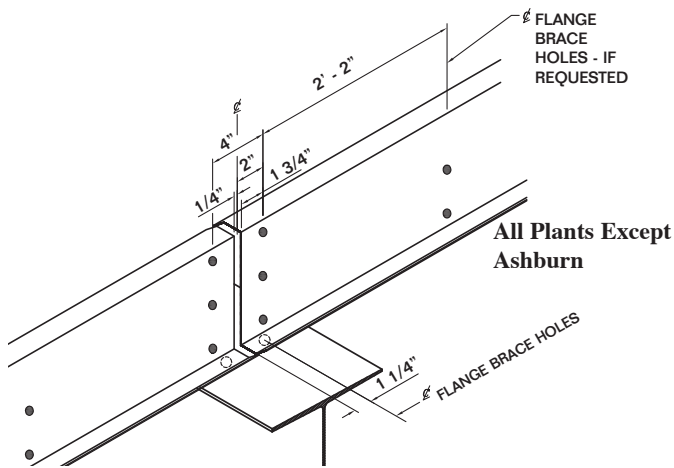

Note: all center holes shown are punched in 10" & 12" Cee or Zee only.

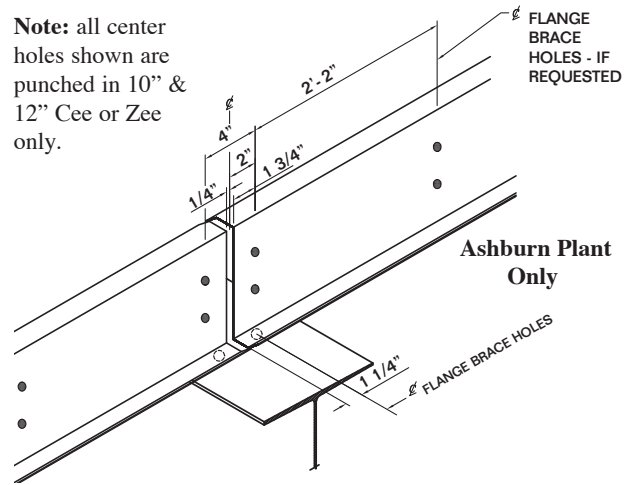

Order Information: 1. To determine actual order length, subtract 1/2" from bay spacing.
2. To determine end bay actual order length, subtract 1/2" from bay spacing.

SHORT LAP

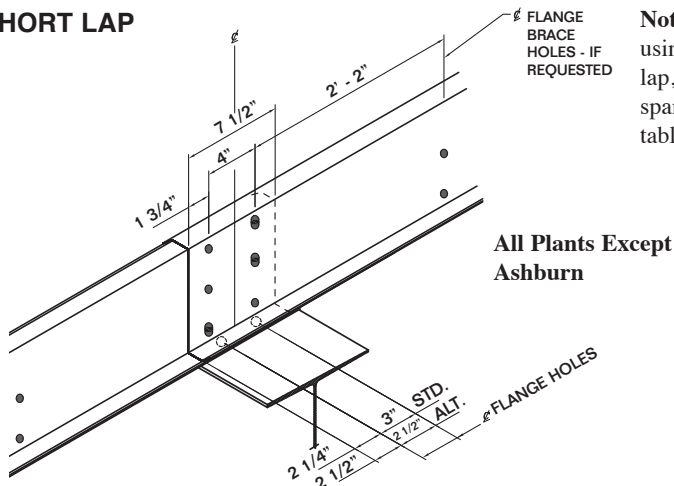

Note: when using short lap, simple span load tables apply.

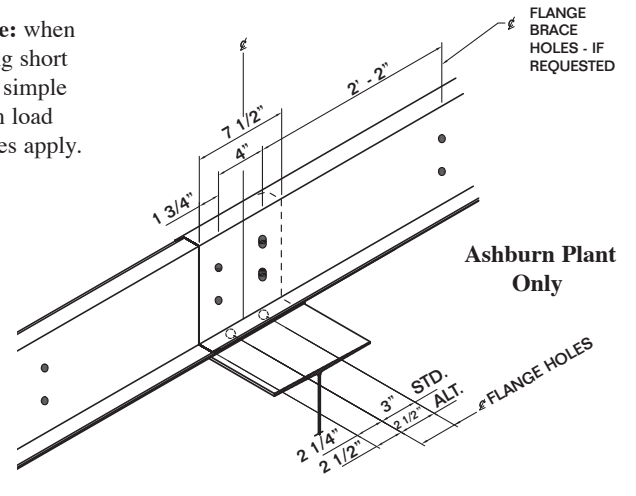

Order Information: 1. To determine actual order length, add 7 1/2" to bay spacing.
2. To determine end bay actual order length, subtract 1/4" for setback, then add 3 3/4" to bay spacing.

LONG LAP

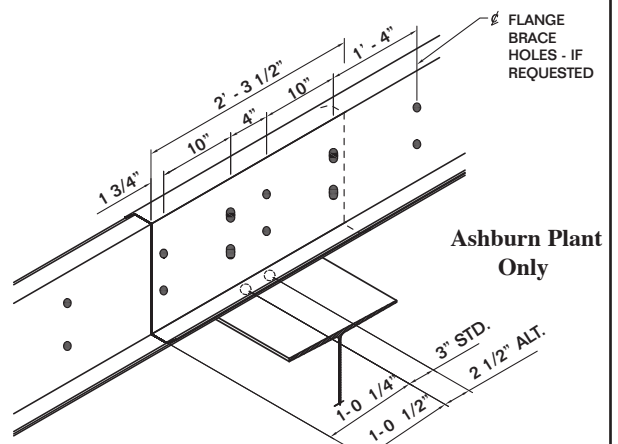
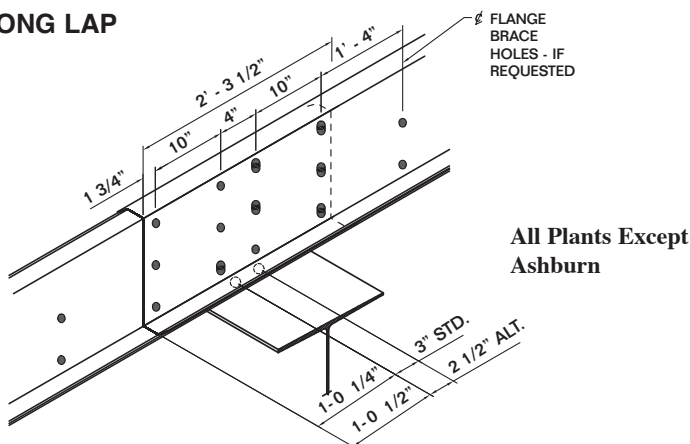

Order Information: 1. To determine actual order length, add 2'-3 1/2" to bay spacing.
2. To determine end bay actual order length, subtract 1/4" for setback, then add 1'-1 3/4" to bay spacing.

STANDARD PUNCHING PATTERNS ORDERING INFORMATION CEES AND ZEES

MAX LAP

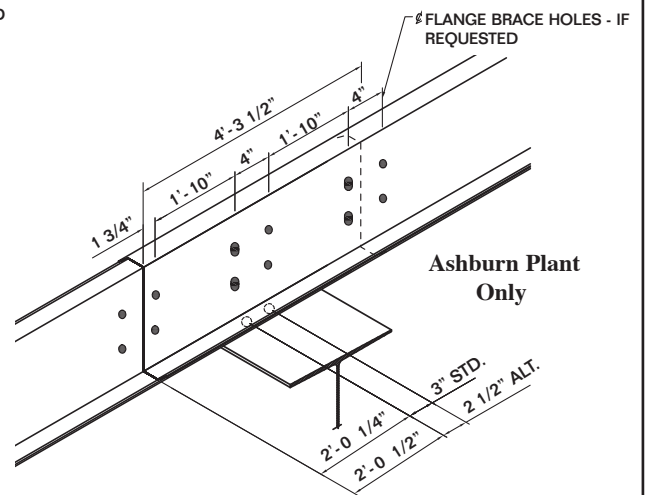
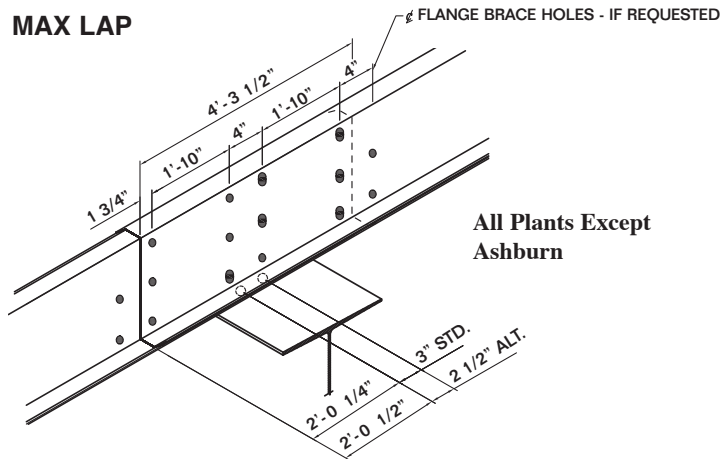

Order Information: 1. To determine actual order length, add 4'- 3 1/2" to bay spacing.
2. To determine end bay actual order length, subtract 1/4" for setback, then add 2'- 1 3/4" to bay spacing.

SUPER LAP

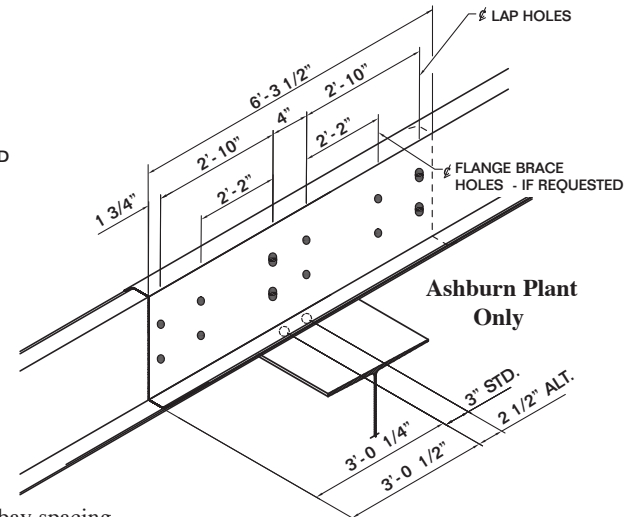
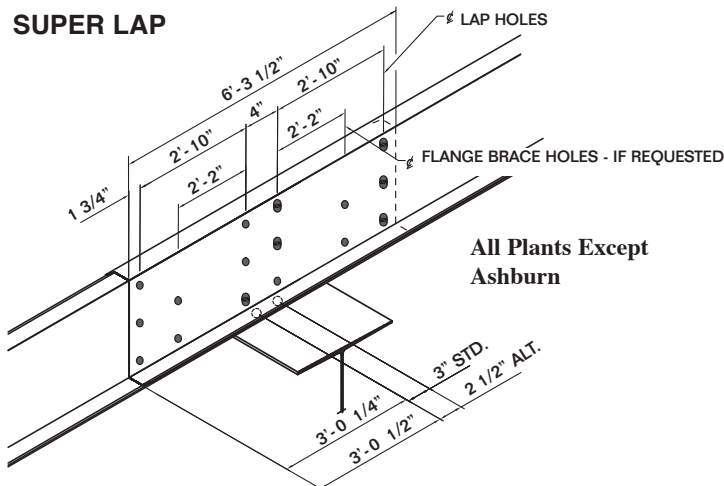

Order Information: 1. To determine actual order length, add 6'- 3 1/2" to bay spacing.
2. To determine end bay actual order length, subtract 1/4" for setback, then add 3'- 1 3/4" to bay spacing.

BOLTS:

Bolts Per Lap Type
Bolts: 1/2" Diameter

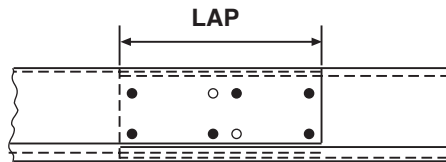

For 6" thru 9" Deep Zees, 6 Bolts required per Lap (and all depths in Ashburn).

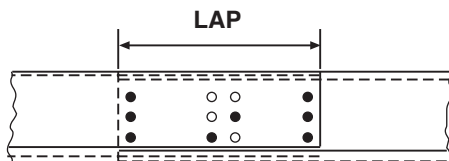

For 10" thru 12" Deep Zees, 8 Bolts
required per Lap.

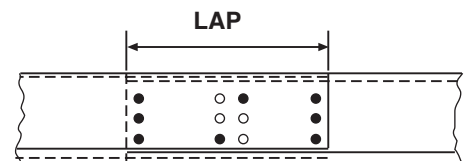

Alternate for 10" Deep Zees, 8 Bolts
required per Lap.

PUNCHING INFORMATION

* SIMPLE SPAN PUNCH

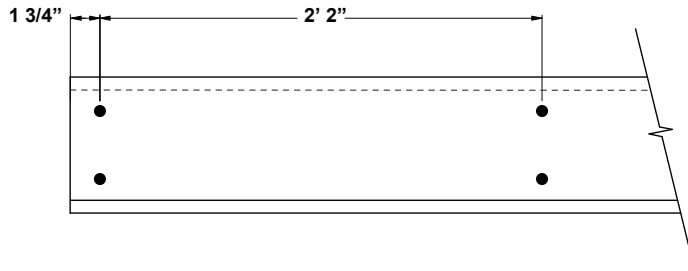

* SHORT LAP PUNCH

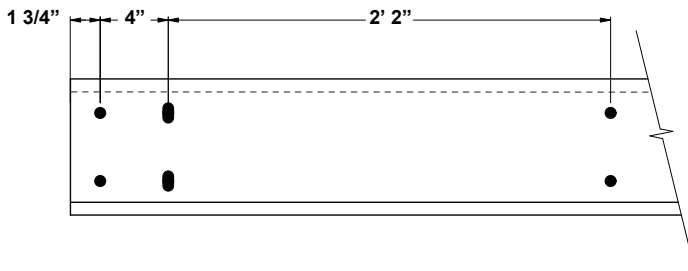

* LONG LAP PUNCH

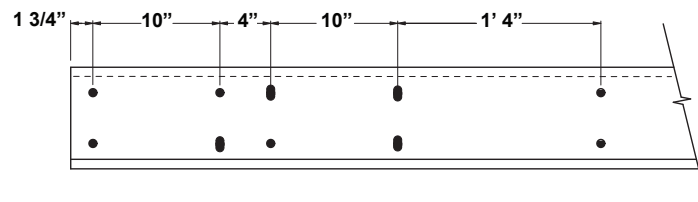

* MAX LAP PUNCH

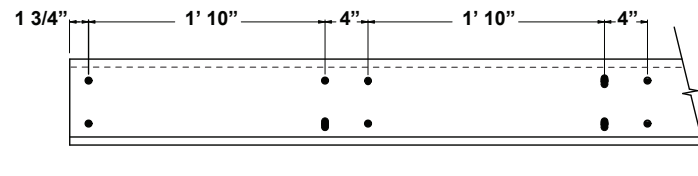

* SUPER LAP PUNCH

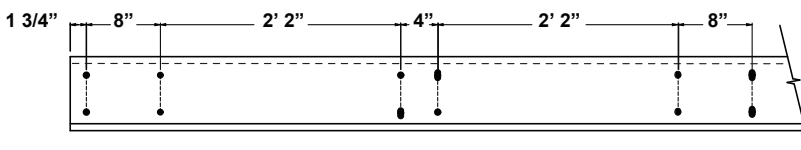

COMBINATION PUNCHING

* UNIVERSAL PUNCH

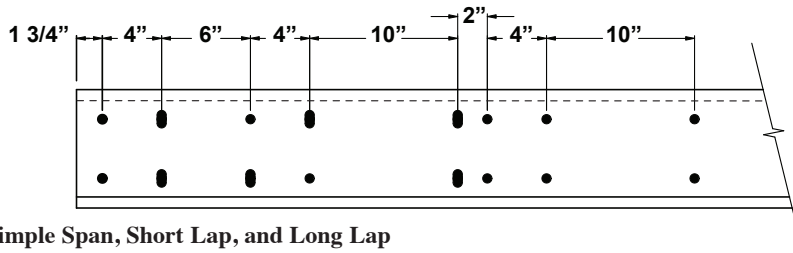

Includes: Simple Span, Short Lap, and Long Lap

* END BAY PUNCH

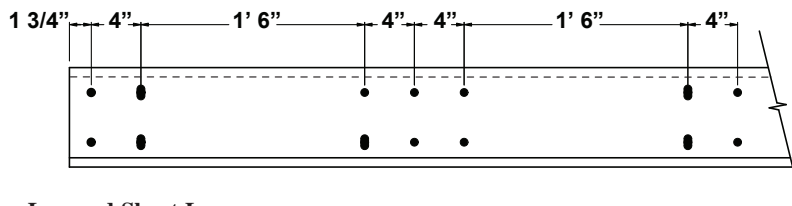

Includes: Max Lap and Short Lap

* STANDARD PUNCH

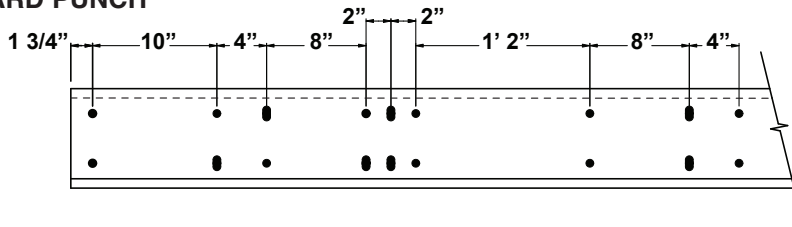

Includes: Max Lap and Long Lap

* EXTENDED PUNCH

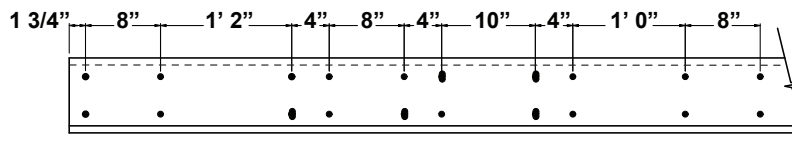

Includes: Super Lap and Max Lap

* CLASSIC PUNCH

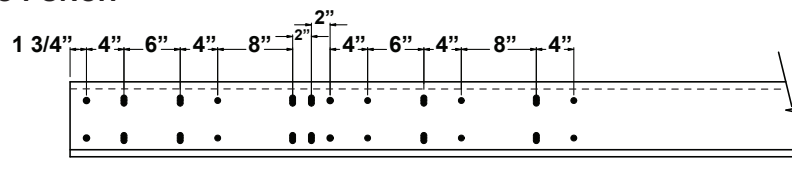

Includes: Simple Span, Short Lap, Long Lap, and Max Lap

* COMPREHENSIVE PUNCH

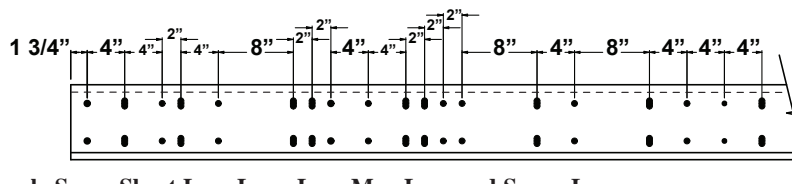

Includes: Simple Span, Short Lap, Long Lap, Max Lap, and Super Lap

HAT AND CHANNEL / MAC-GIRT / SUB-GIRT

Hat and Channel

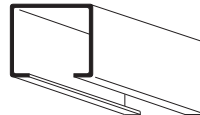
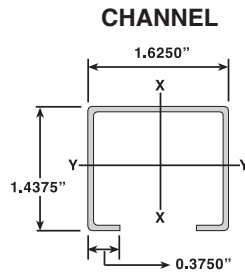
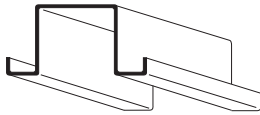
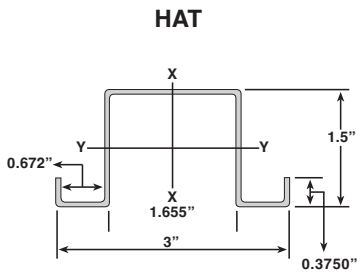

Section	Dimension	Gauge
Hat	1 3/4" x 1 1/2"	16
Hat	1 3/4" x 1 1/2"	18
Hat	1 3/4" x 1 1/2"	20
Channel	1 5/8" x 1 7/16"	16
Channel	1 5/8" x 1 7/16"	18

- McElroy Metal's standard hat and channel line is ideal for use in mansard, roof and canopy applications.
- Hats and channels are galvanized and come in a variety of gauges.
- Minimum length is 10'.
- Maximum length is 24'.
- Manufactured in Sunnyvale, Texas.

Mac-Girt

- Available in 16, 18, and 20 Gauges.
- Minimum length is 10'.
- Maximum length is 24'.
- Manufactured in Lewisport, Kentucky.

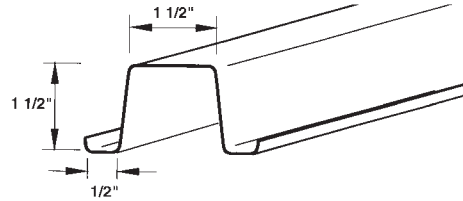

Sub-Girt

MSG 1

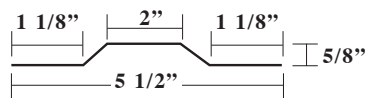

- 16, 18 & 20 Gauge
- 5/8" x 5 1/2"
- Galvanized
- Minimum length is 10'
- Maximum length is 24'

MSG 2

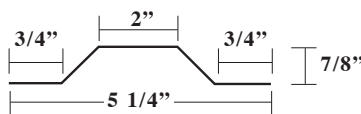

- 18 & 20 Gauge
- 7/8" x 5 1/4"
- Galvanized
- Minimum length is 10'
- Maximum length is 24'

MSG 3

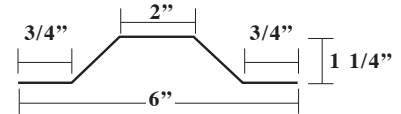

- 18 Gauge
- 1 1/4" x 6"
- Galvanized
- Minimum length is 10'
- Maximum length is 24'

Please note: MSG1, MSG2, and MSG3 are manufactured in Lewisport, Kentucky.

Furring Zee, Framing Track, and Framing Channel

FURRING ZEE

Item #: 21711

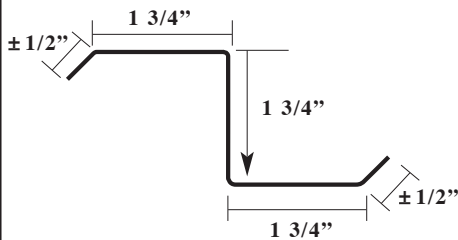

- 16 Gauge
- LF
- Galvanized
- Minimum length is 1 1/2'
- Maximum length is 20'

FRAMING TRACK

Item #: 22800

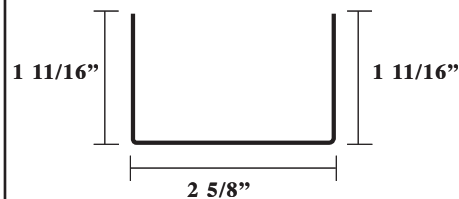

- 16 Gauge
- 2 5/8" x 1 11/16" x LF
- Galvanized
- Minimum length is 1'
- Maximum length is 20'

FRAMING CHANNEL

Item #: 232874

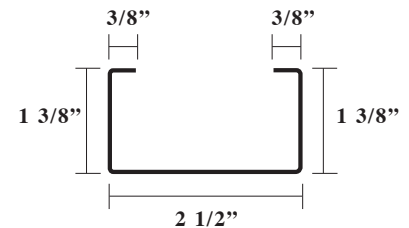

- 16 Gauge
- 2 1/2" x 1 3/8" x LF
- Galvanized
- Minimum length is 1'
- Maximum length is 20'

Manufactured in Houston, Texas

Hat Channel

HAT CHANNEL CEES AND ZEE CLIPS

Hat Channel	Dimension	GA
Red Primed Hat Channel	3" x 1"	14
Red Primed Hat Channel	6" x 1"	14
Red Primed Hat Channel	9" x 1"	14
Galvanized Hat Channel	6" x 1"	14
Galvanized Hat Channel	9" x 1"	14

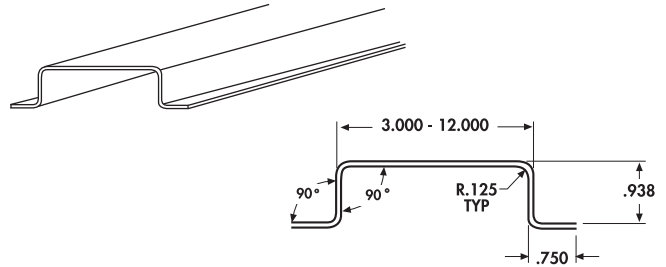

• Manufactured in Clinton, Illinois.

Cee and Zee Clips

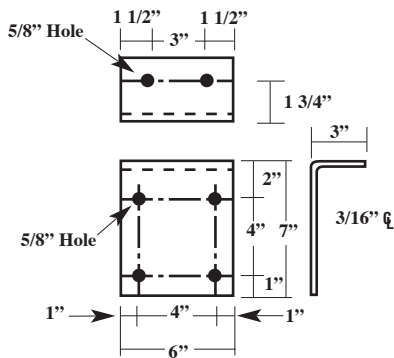

3" x 7" x 3/16" x 0' - 6"
WT. = 3.22
Item #: 76810

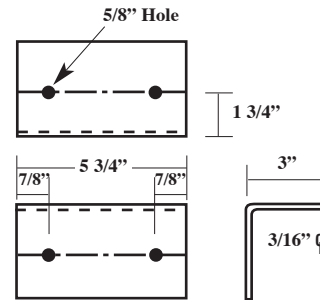

3" x 3" x 3/16" x 0' - 5 3/4"
WT. = 1.92
Item #: 76800

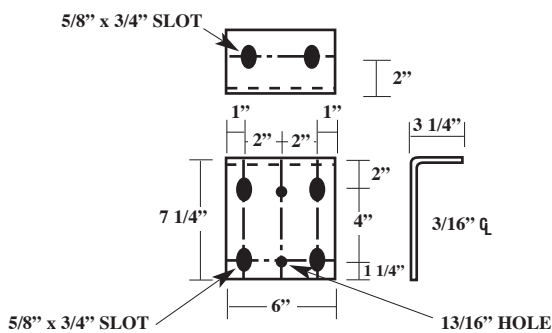

3 1/4" x 7 1/4" x 3/16" x 0' - 6"
WT. = 3.52
Item #: 76830

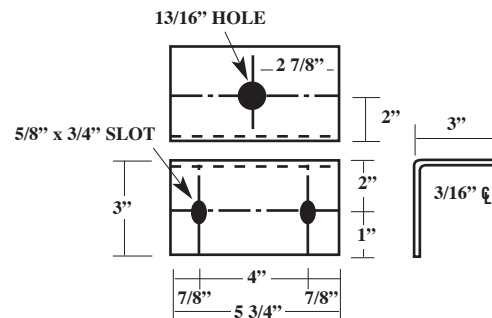

3" x 3" x 3/16" x 0' - 5 3/4"
WT. = 2.22
Item #: 76820

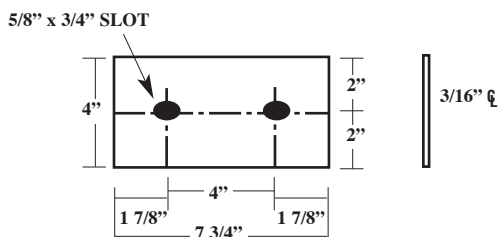

7 3/4" x 3/16" x 0' - 4"
WT. = 1.70
Item #: 76850

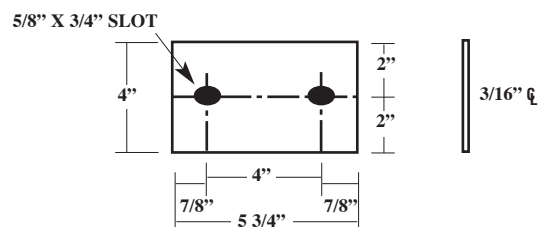

5 3/4" x 3/16" x 0' - 4"
WT. = 1.28
Item #: 76840



SUBSTRUCTURAL INFORMATION

STANDARD CEE AND ZEE AVAILABILITY

ADELANTO	<ul style="list-style-type: none"> - Web size options vary from 4" to 24". - Flange size options vary from 2" to 5". - Adelanto Substructural XL information may be found on page 11 through page 13 of this book. - Return legs are 13/16" +/- 1/8". - Web punching is standard - flange punching must be requested at time of order. - 4" web - contact a McElroy Representative. - 6" to 9" web gets standard 2 hole pattern (Example: 8" web is 2-4-2 pattern). - 10" web with 2", 2 1/2", or 3" flange - standard 2 hole punch (3-4-3 pattern) or standard 3 hole punch (1-4-4-1 pattern). - 10" web with 4" flange - standard 3 hole punch only (1-4-4-1 pattern). - 12" web gets standard 3 hole punch (2-4-4-2 pattern). - 12" web alternate is 2 hole punch (2-4-2 pattern). - Minimum length - 5'. Maximum length - 45' when rollformed. Contact a McElroy Representative regarding longer lengths. - 32' maximum length for special press broke purlins. - Stocks galvanized purlin coil only.
ASHBURN	<ul style="list-style-type: none"> - Web size options vary from 4" to 14". - Flange size options vary from 2" to 4" on all web sizes. Can do a 5" flange size for the following larger web sizes only (8" to 14" wide webs). - Return legs are 13/16" +/- 1/8". - Web and flange can be punched in any location - flange punching must be requested at time of order. - Minimum length - 5'. Maximum length - 45' when rollformed. Contact a McElroy Representative regarding longer lengths. - 32' maximum length for special press broke purlins.
BOSSIER	<ul style="list-style-type: none"> - Web size options vary from 4" to 20". - Flange size options vary from 2" to 5". - Bossier Substructural XL information may be found on page 11 through page 13 of this book. - Return legs are 13/16" +/- 1/8". - Web punching is standard - flange punching must be requested at time of order. - 4" web - contact a McElroy Representative. - 6" to 9" web - standard 2 hole punch (Example: 8" web has 2-4-2 pattern). - 10" web with 2", 2 1/2", or 3" flange - standard 2 hole punch (3-4-3 pattern) or standard 3 hole punch (1-4-4-1 pattern). - 12" web with 2" or 2 1/2" gets standard 3 hole punch (2-4-4-2 pattern). - 12" web with flange greater than 2 1/2" can not be punched. - Minimum length - 6'. Parts under 6' will be stitched together with a partial cut. - Maximum length - 45' when rollformed. Contact a McElroy Representative regarding longer lengths. - 32' maximum length for special press broke purlins.
CLINTON	<ul style="list-style-type: none"> - Web size options vary from 4" to 14" (16" coming soon. Please confirm 16" availability.) - Flange size options vary from 2" to 4". - Clinton Substructural XL information may be found on page 11 through page 13 of this book. - Return legs are 13/16" +/- 1/8". - Web punching is standard - flange punching must be requested at time of order. - 4" web - contact a McElroy Representative. - 6" to 9" web gets standard 2 hole pattern (Example: 8" web is 2-4-2 pattern). - 10" web with 2", 2 1/2", 3", 4" flange - standard 2 hole punch (3-4-3 pattern) or standard 3 hole punch (1-4-4-1 pattern). - 12" web gets standard 3 hole punch (2-4-4-2 pattern). - Minimum length - 6'. Parts under 6' will be stitched together with a partial cut. - Maximum length - 45' when rollformed. Contact a McElroy Representative regarding longer lengths. - 32' maximum length for special press broke purlins.
WINCHESTER	<ul style="list-style-type: none"> - Web size options vary from 4" to 12". - Flange size options - 1 1/2", 2", 2 1/2", 3", 3 1/2" (zee only). - 2", 2 1/2", 3 1/2", 4" (cee only). - Return legs are 13/16" +/- 1/8". - Web punching is standard - flange punching must be requested at time of order. - 4" web - contact a McElroy Representative. - 6" to 9" web gets standard 2 hole pattern (Example: 8" web is 2-4-2 pattern). - 10" web with 2", 2 1/2". or 3" flange - standard 2 hole punch (3-4-3 pattern) or standard 3 hole punch (1-4-4-1 pattern). - 10" web with 4" flange - standard 3 hole punch only (1-4-4-1 pattern). - 12" web gets standard 3 hole punch (2-4-4-2 pattern). - Minimum length - 5'. Maximum length - 45' when rollformed. Contact a McElroy Representative regarding longer lengths. - 26' maximum length for special press broke purlin.
SPECIAL CEES AND ZEES	<ul style="list-style-type: none"> - Confirm critical dimensions. - Formula: web + flange + flange + 15/16" = coil girth. - Contact a McElroy Representative regarding special punching.

MCELROY METAL SUBSTRUCTURAL XL COMPONENTS

- Manufactured in Adelanto, CA, Bossier City, LA, and Clinton, IL only.

READY TO BOLT SUBSTRUCTURAL XL COMPONENTS

Setting the new industry standard, McElroy Metal's substructural XL components generate labor and material savings that will boost sales revenue and enhance bottom line performance.

- 10, 12, 14, and 16 gauge members with webs up to 24" in Adelanto, CA, 20" in Bossier City, LA, and 16" in Clinton, IL enables value engineering and optimization opportunities.

The following chart is applicable for structural applications. Other gauge / max web combinations are available for non-structural applications:

ADELANTO, CA				
GAUGE	10	12	14	16
MAX WEB	24"	20"	13"	11"

BOSSIER CITY, LA				
GAUGE	10	12	14	16
MAX WEB	20"	20"	13"	11"

CLINTON, IL				
GAUGE	10	12	14	16
MAX WEB	16"	16"	13"	11"

- Factory flange notching reduces costly secondary fabrication and/or field torching and cutting.
 - Top and / or bottom flange
 - Leading and / or trailing end
- Flexible punching capabilities reduces costly field drilling.
 - Standard holes from 7/32" to 1 1/4"
 - Slot punching from 5/8" x 3/4" to 7/16" x 2"
 - 2" and 3" hole punch to accommodate sprinklers, conduit and other pass-through utilities.

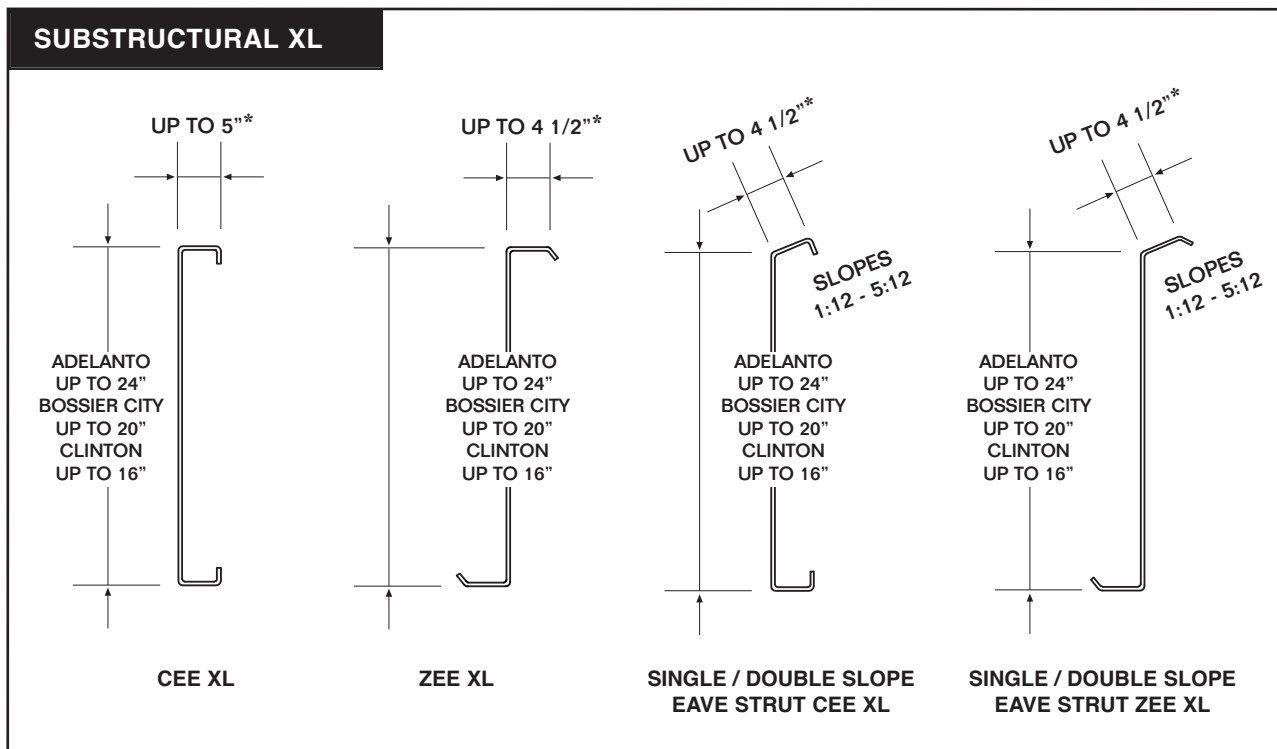

* MAX FLANGE WIDTH MAY VARY BY WEB WIDTH

SUBSTRUCTURAL INFORMATION

MCELROY METAL SUBSTRUCTURAL XL PUNCHING CAPABILITIES

PUNCHING:

HOLE PUNCHING
ANYWHERE IN WEB
OR FLANGE

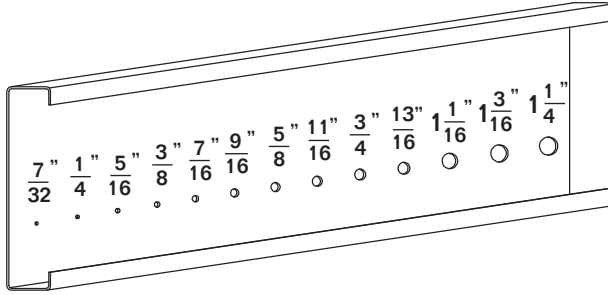

VERTICAL (PERPENDICULAR)
SLOTTING ANYWHERE IN
WEB OR FLANGE

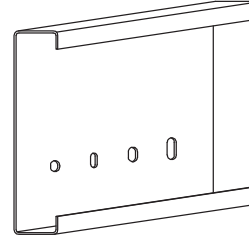

DIMENSIONS:
5/8" X 3/4"
7/16" X 1"
5/8" X 1"
5/8" X 1 1/2"

HORIZONTAL SLOTTING
ANYWHERE IN WEB OR
FLANGE

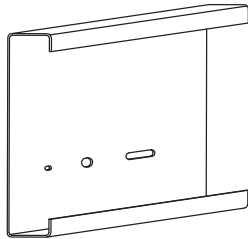

DIMENSIONS:
9/32" X 7/16"
5/8" X 3/4"
7/16" X 2"

SPRINKLER / UTILITY
PASS THROUGH
ANYWHERE IN WEB

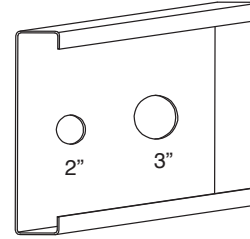

MCELROY METAL SUBSTRUCTURAL XL NOTCHING CAPABILITIES

NOTCHING:

ALL XL MEMBERS CAN BE NOTCHED
TOP AND / OR BOTTOM
LEADING AND / OR TRAILING ENDS

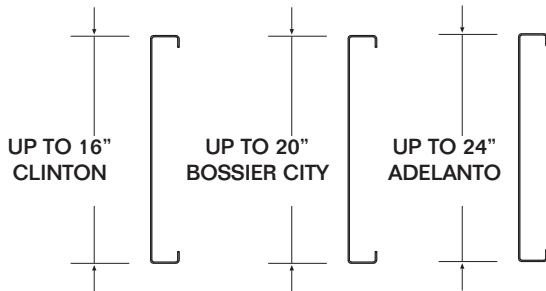

1 1/2" MINIMUM -
NO MAXIMUM

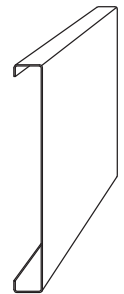
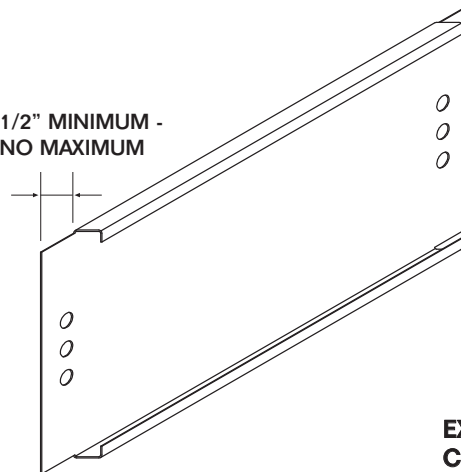

EXAMPLE SHOWN -
CEE PURLIN XL

**NOTCHING:
SUBSTRUCTURAL XL ANGLE AND CHANNEL**

BASE ANGLE

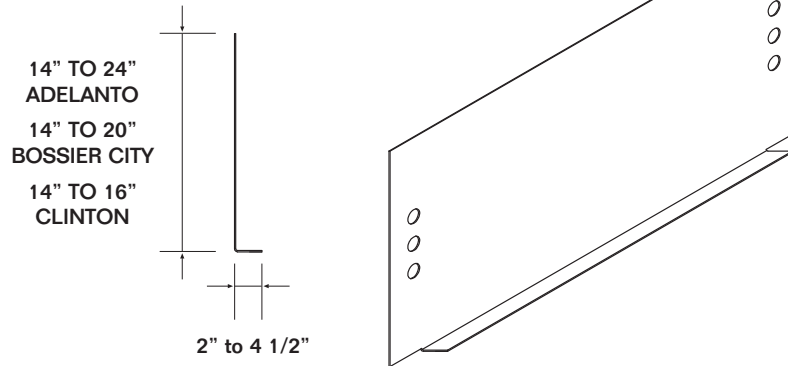

U-CHANNEL

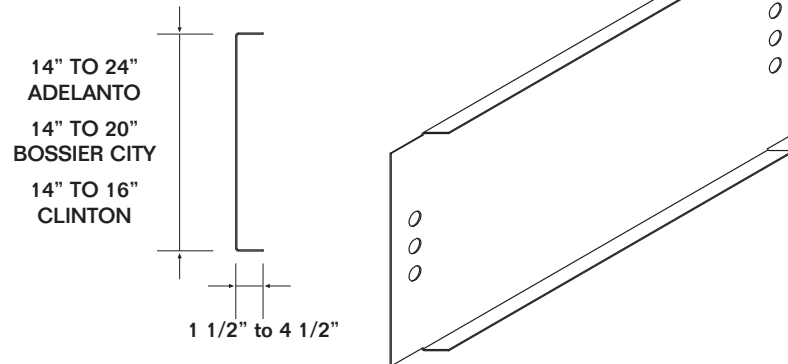

NOTES:



SUBSTRUCTURAL INFORMATION

NOTES:



☆ MANUFACTURING LOCATIONS ● SERVICE CENTERS ★ MANUFACTURING AND SERVICE CENTER



CORPORATE OFFICE
1500 HAMILTON RD.
BOSSIER CITY, LA 71111

MANUFACTURING LOCATIONS

ADELANTO, CA	ASHBURN, GA	BOSSIER CITY, LA	CLINTON, IL	DIAMOND, MO
HOUSTON, TX	LEWISPORT, KY	LOCKHART, TX	MARSHALL, MI	MAUSTON, WI
MERKEL, TX	PEACHTREE CITY, GA	SUNNYVALE, TX	WINCHESTER, VA	



17031 Koala Road Adelanto, CA 92301	5215 Leo St. Alexandria, LA 71301	1007 Wilso Dr, Baltimore, MD 21223	1500 Hamilton Rd. Bossier City, LA 71111
3052 Yadkin Road Chesapeake, VA 23323	9476 Meadowbrook Rd. Clinton, IL 61727	3215 Highway 59 Diamond, MO 64840	390 N. Valley Dell Dr. Fenton, MO 63026
409 Lovejoy Road Ft. Walton Beach, FL 32548	3014 Lincoln Court Garland, TX 75041	1440 Aldine Bender Road Houston, TX 77032	221 Benelli Drive Hutto, TX 78634
10504 E. 59th Street Indianapolis, IN 46236	32 Industrial Circle Lancaster, PA 17601	9435 US Hwy. 60 W. Lewisport, KY 42351	2701 Cahill Street Lockhart, TX 78644
1020 Veterans Street Mauston, WI 53948	5123 Terminal Dr. McFarland, WI 53558	514 Cave Road Nashville, TN 37210	8304 Hwy. 70 E. North Little Rock, AR 72117
613 North Bierdeman Rd. Pearl, MS 39208	8511 Industrial Drive Pearland, TX 77584	2755 Hwy 60 Pendergrass, GA 30567	7450 Tower Street Richland Hills, TX 76118
8200 Berry Ave. Suite 100 Sacramento, CA 95828	1365 Dean Forest Rd. Savannah, GA 31405	7355 Oakley Industrial Blvd. Union City, GA 30291	1144 Silstar Rd. West Columbia, SC 29170
325 McGhee Rd. Winchester, VA 22603			

Website: www.mcelroymetal.com • E-mail: info@mcelroymetal.com