

MSR TRIM INDEX

<u>DWG #:</u>	<u>DESCRIPTION:</u>	<u>IMAGE #:</u>
MSRTW-0001	Base Trim	407
MSRTW-0002	Head Trim	408
MSRTW-0003	Cap / Jamb Trim	409
MSRTW-0004	Splice Trim	410
MSRTW-0005	Inside Corner Trim	411
MSRTW-0006	Outside Corner Trim	412
MSRTW-0007	Furring Zee	413
MSRTW-0008	1 1/2" J-Trim	414
MSRTW-0009	Eave Trim	415

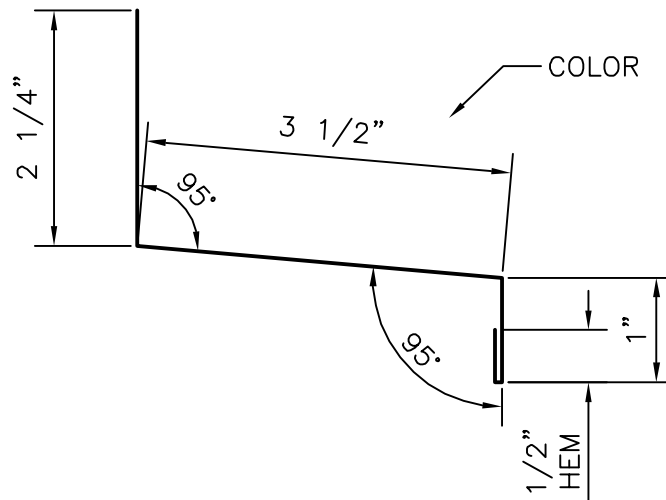

BASE TRIM

PANEL PROFILES	GAUGE
MSR PANEL	24

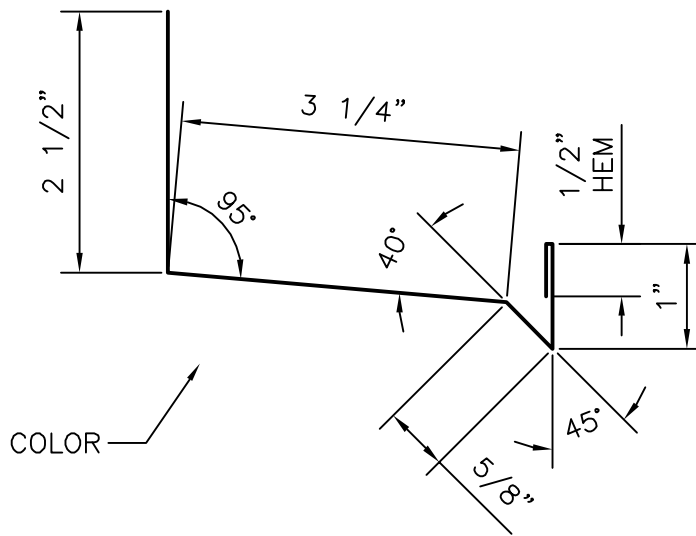

HEAD TRIM

PANEL PROFILES	GAUGE
MSR PANEL	24

11-13-14 rev.
6-04-13 rev.
1-24-11

GIRTH: 7 7/8"
BENDS: 90° AND AS SPECIFIED

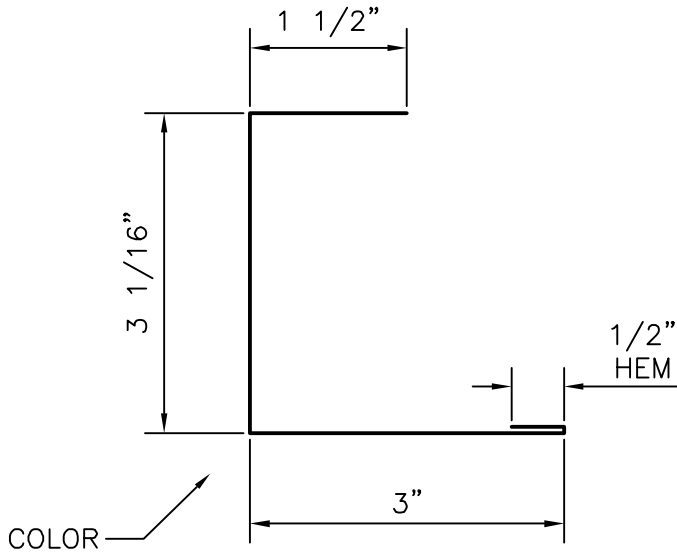

CAP / JAMB TRIM

PANEL PROFILES	GAUGE
MSR PANEL	24

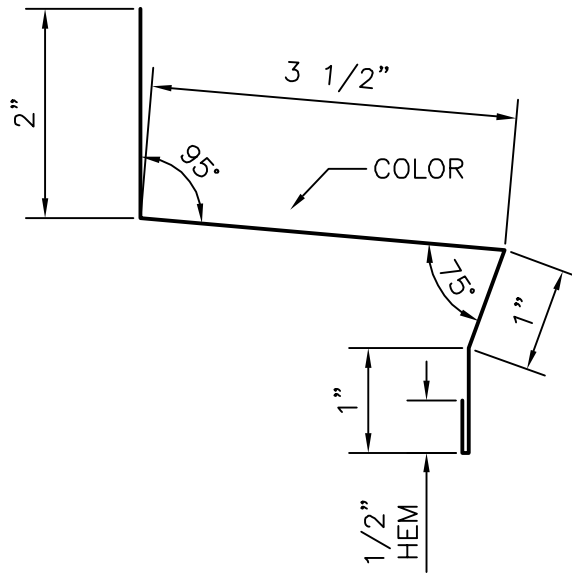

SPLICE TRIM

PANEL PROFILES	GAUGE
MSR PANEL	24

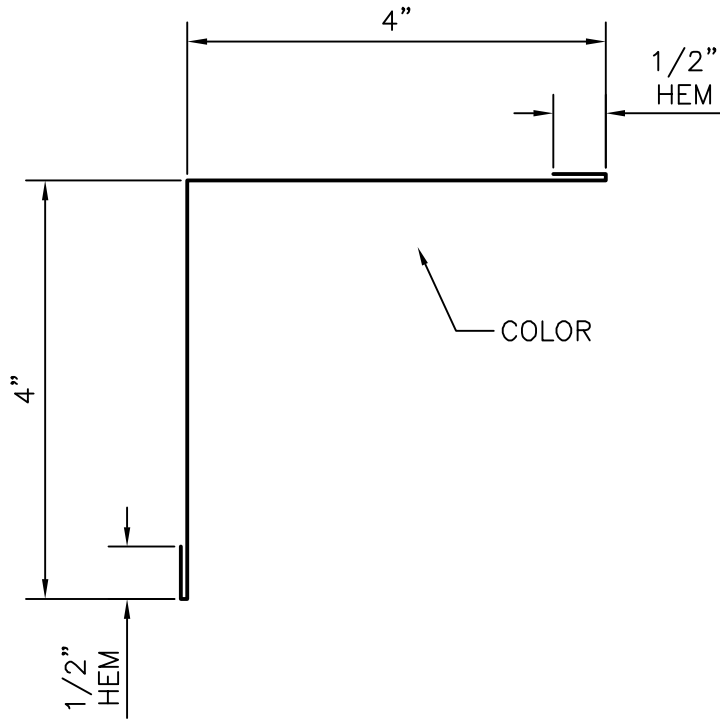

INSIDE CORNER TRIM

PANEL PROFILES	GAUGE
MSR PANEL	24

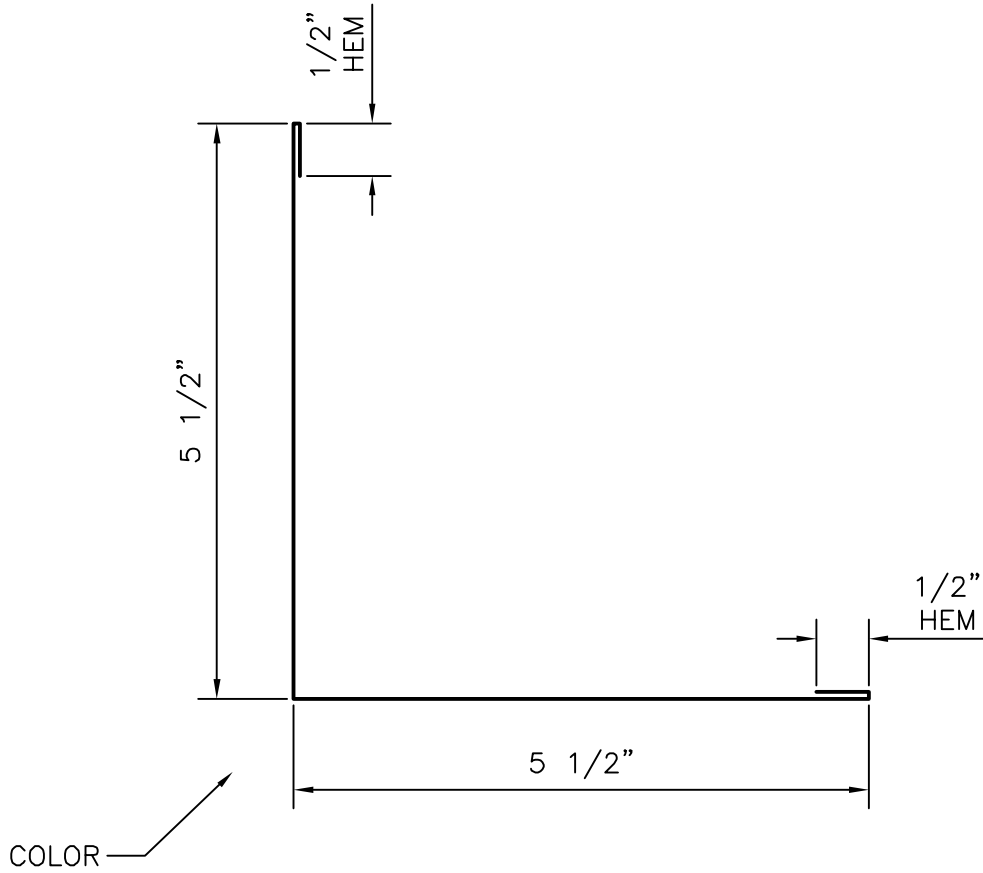

OUTSIDE CORNER TRIM

PANEL PROFILES	GAUGE
MSR PANEL	24

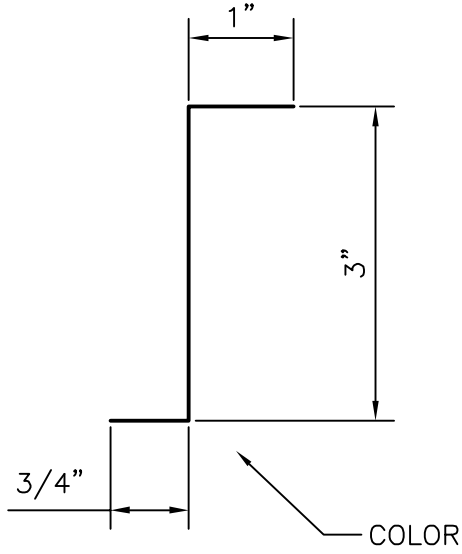

FURRING ZEE

PANEL PROFILES	GAUGE
MSR PANEL	24

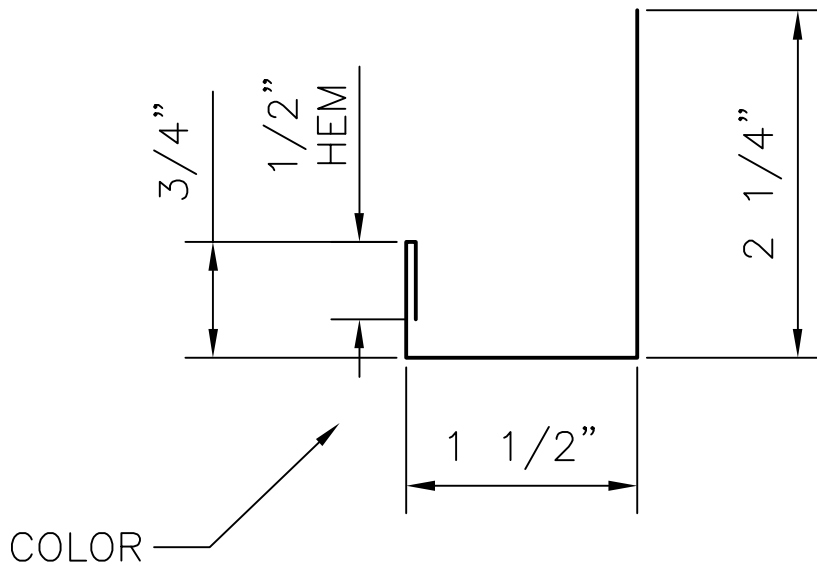

1 1/2" J-TRIM

PANEL PROFILES	GAUGE
MSR PANEL	24

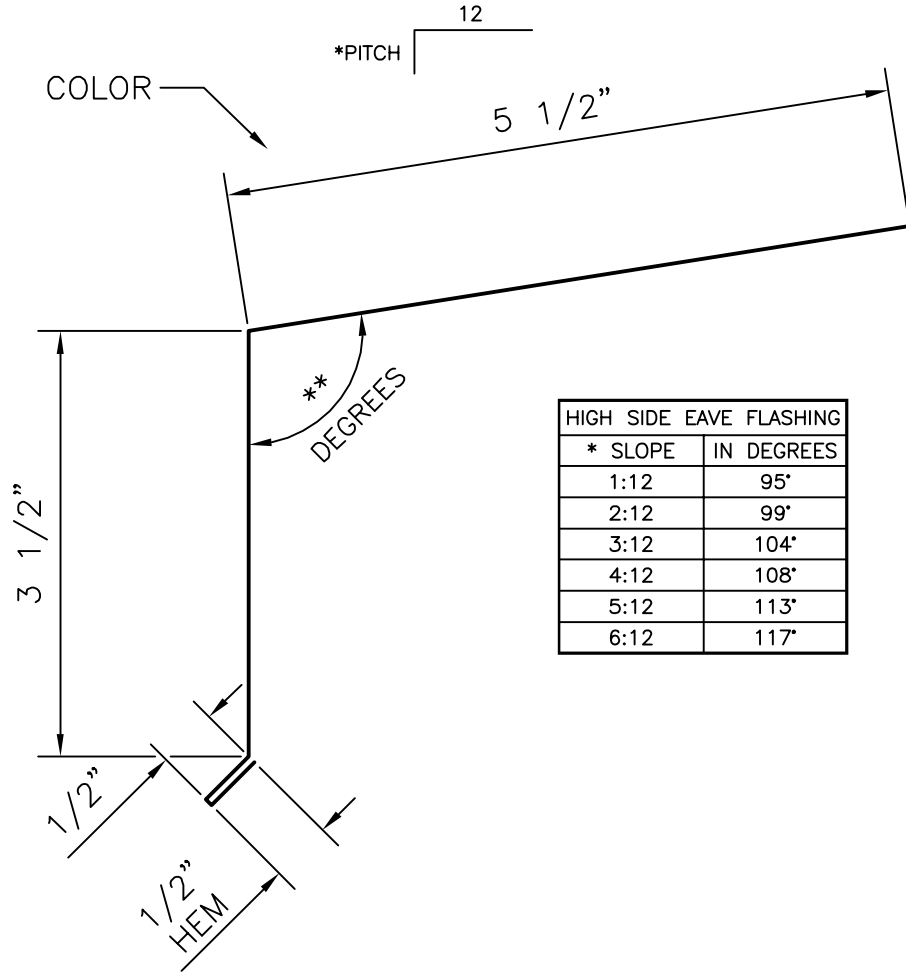

EAVE TRIM

PANEL PROFILES	GAUGE
MRS PANEL	24