

## Maxima 2" ADV Panel

## Product Data

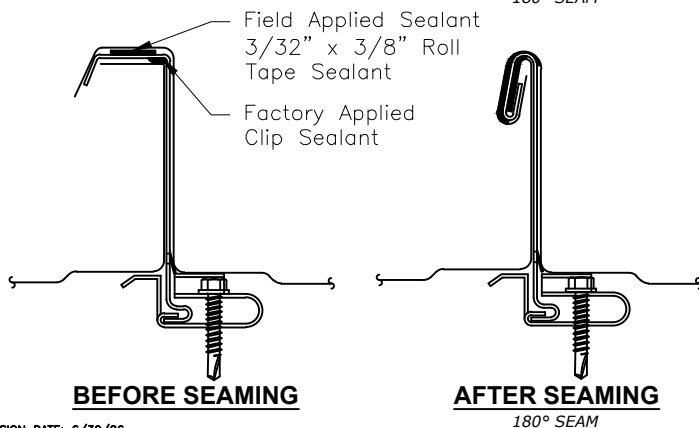
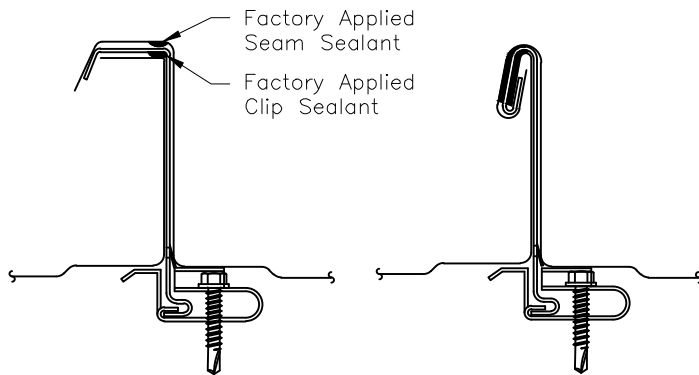
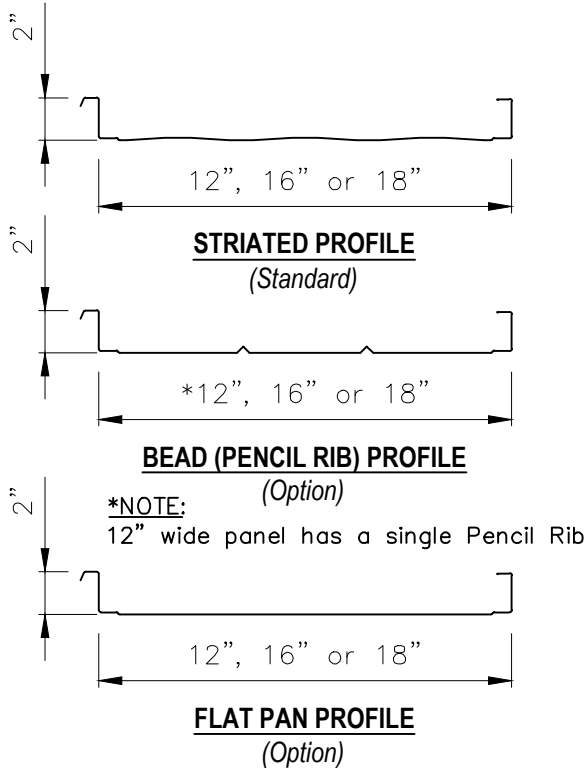

### Applications

Mechanically Seamed roof/wall panel used on slopes down to 1/2:12. Continuous length up to 80'. Convex curving only - 25ft minimum radius.

### Substrates

Solid Wood Decking, Metal Deck and Rigid Insulation/Metal Deck or Open Framing.

### Material

Standard - 24 GA. ASTM A792 (50 ksi steel) AZ55 - Bare  
AZ50 - Painted  
Optional - 22 GA. ASTM A792 (50 ksi steel) AZ55 - Bare  
AZ50 - Painted  
- .032 Aluminum (Sunnyvale Plant Only)

### Manufacturing

Roll formed in factory or at jobsite.  
Available Factory Eave Notching of 1 1/2"

### Finishes

Acrylic Coated Galvalume®  
Fluoropolymer (Kynar 500® PVDF resin-based)

### Panel Conditions

Striated, Pencil Rib, or Flat  
Oil canning is inherent in all metal panels and is not cause for panel rejection. A signed oil canning acknowledgement will be required for all orders prior to production.

### Testing \*

Uplift: ASTM E1592, UL 580 Class 90  
Air & Water Infiltration: ASTM E1680, ASTM E1646  
Fire Resistance: UL 263 & UL 790 Class A  
Impact Testing: UL 2218 Class 4  
Florida Product Approval: FL 1747.4

\*Testing and Approvals are product specific. Please inquire for details.\*

### NOTE:

Factory applied seam sealant can only be ordered on panels that will NOT be curved. If curving these panels, the installer must field apply 3/32" x 3/8" Roll Tape Butyl Sealant.

### NOTE:

All data represented on this sheet may not be applicable to all widths and gauges. Please contact McElroy Metal for more information.

\*Requires a Mechanical Seamer and Hand Seamer to finish seam.\*

## Maxima 2" ADV Panel (Continued)

## Product Data

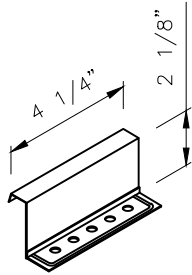

**UTILITY FIXED CLIP**

22 GA. Galv. G90 - ASTM A653 (50 ksi)  
22 GA. Stainless Steel - ASTM A666 (50 ksi)

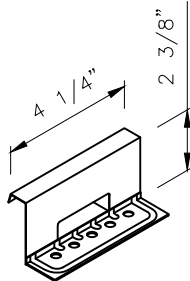

**LOW FIXED CLIP**

22 GA. Galv. G90 - ASTM A653 (50 ksi)  
22 GA. Stainless Steel - ASTM A666 (50 ksi)

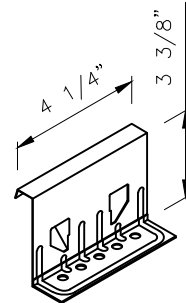

**HIGH FIXED CLIP**

22 GA. Galv. G90 - ASTM A653 (50 ksi)  
22 GA. Stainless Steel - ASTM A666 (50 ksi)

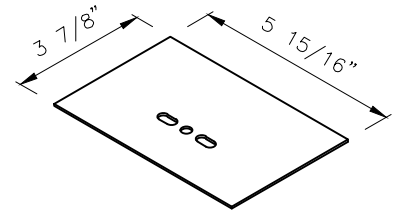

**BEARING PLATE**

16 GA.  
RED PRIMED - ASTM A1011 (55 ksi)  
GALVANIZED - ASTM A653 (55 ksi)

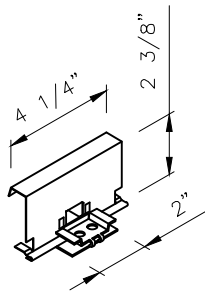

**LOW FLOATING CLIP**

2-Piece

Clip: 22 GA. Galvanized G90 - ASTM A653 (50 ksi)  
Clip: 22 GA. Stainless Steel - ASTM A666 (50 ksi)  
Base: 16 GA. Galvanized G90 - ASTM A653 (50 ksi)

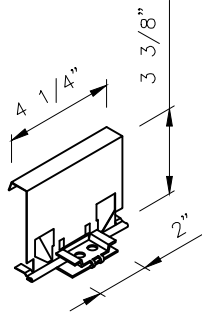

**HIGH FLOATING CLIP**

2-Piece

Clip: 22 GA. Galvanized G90 - ASTM A653 (50 ksi)  
Clip: 22 GA. Stainless Steel - ASTM A666 (50 ksi)  
Base: 16 GA. Galvanized G90 - ASTM A653 (50 ksi)

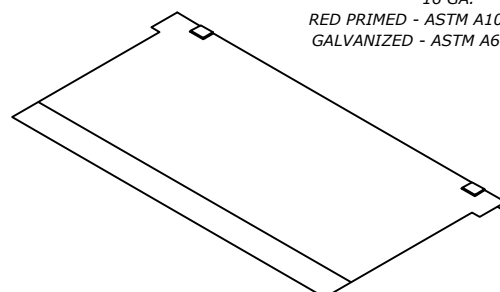

**BACK-UP PLATE**

16 GA.

GALVANIZED - ASTM A653 (55 ksi)  
USE WITH 16" OR 18" PANELS ONLY

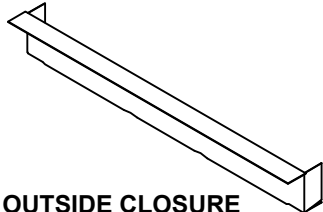

**OUTSIDE CLOSURE**

24 GA. - ASTM A792 (50 ksi)  
USE WITH 16" AND 18"  
WIDE PANELS

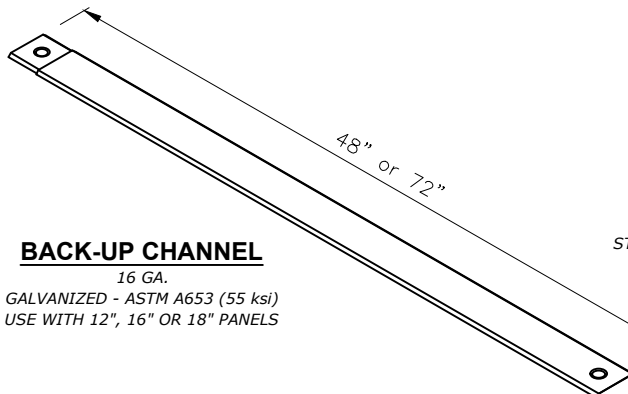

**BACK-UP CHANNEL**

16 GA.

GALVANIZED - ASTM A653 (55 ksi)  
USE WITH 12", 16" OR 18" PANELS

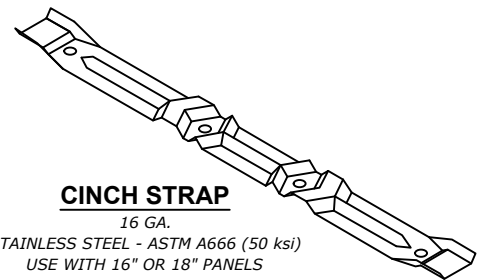

**CINCH STRAP**

16 GA.

STAINLESS STEEL - ASTM A666 (50 ksi)  
USE WITH 16" OR 18" PANELS

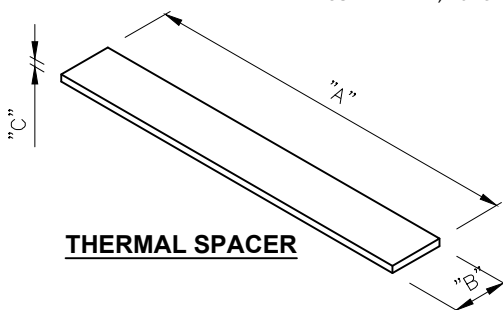

**THERMAL SPACER**

THERMAL SPACER SIZE CHART

PANEL	"A"	"B"	"C"
12"	*14 7/8"	2 1/2"	3/8", 5/8", 1" or 1 3/8"
16"	14 7/8"	2 1/2"	3/8", 5/8", 1" or 1 3/8"
18"	16 7/8"	2 1/2"	3/8", 5/8", 1" or 1 3/8"

\*NOTE: FOR 12" PANELS, FIELD CUT 14 7/8" SPACERS  
DOWN TO 10 7/8" LONG.

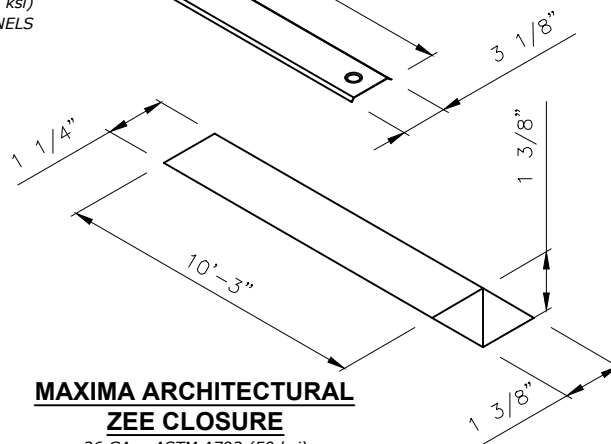

**MAXIMA ARCHITECTURAL ZEE CLOSURE**

26 GA. - ASTM A792 (50 ksi)  
FIELD CUT TO FORM OUTSIDE CLOSURES FOR  
12", 16" AND 18" WIDE PANELS