



DEPARTMENT OF REGULATORY AND ECONOMIC RESOURCES (RER)
BOARD AND CODE ADMINISTRATION DIVISION

MIAMI-DADE COUNTY
PRODUCT CONTROL SECTION
11805 SW 26 Street, Room 208
Miami, Florida 33175-2474
T (786) 315-2590 F (786) 315-2599

www.miamidade.gov/economy

NOTICE OF ACCEPTANCE (NOA)

McElroy Metal, Inc.
1500 Hamilton Road
Bossier City, LA 71111

SCOPE:

This NOA is being issued under the applicable rules and regulations governing the use of construction materials. The documentation submitted has been reviewed and accepted by Miami-Dade County RER- Product Control Section to be used in Miami Dade County and other areas where allowed by the Authority Having Jurisdiction (AHJ).

This NOA shall not be valid after the expiration date stated below. The Miami-Dade County Product Control Section (In Miami Dade County) and/or the AHJ (in areas other than Miami Dade County) reserve the right to have this product or material tested for quality assurance purposes. If this product or material fails to perform in the accepted manner, the manufacturer will incur the expense of such testing and the AHJ may immediately revoke, modify, or suspend the use of such product or material within their jurisdiction. RER reserves the right to revoke this acceptance if it is determined by Miami-Dade County Product Control Section that this product or material fails to meet the requirements of the applicable building code.

This product is approved as described herein and has been designed to comply with the High Velocity Hurricane Zone of the Florida Building Code.

DESCRIPTION: Maxima, 0.0245” min. Structural Galvalume Steel Roof Panel

APPROVAL DOCUMENT: Drawing #1597, titled “Maxima, 24 Gage Structural Galvalume Steel Roof System”, sheets 1 through 4 of 4, dated July 31, 2008, last revision #4 dated 10/01/2020, prepared, signed and sealed by Bala Sockalingam, P.E., bearing the Miami-Dade County Product Control Revision stamp with the Notice of Acceptance number and the expiration date by the Miami-Dade County Product Control Section.

MISSILE IMPACT RATING: Large and Small Missile Impact Resistant

LABELING: Each panel shall bear a permanent label with the manufacturer's name/logo, Clinton, IL or Peachtree, GA, and the following statement: "Miami-Dade County Product Control Approved", unless otherwise noted herein.

RENEWAL of this NOA shall be considered after a renewal application has been filed and there has been no change in the applicable building code negatively affecting the performance of this product.

TERMINATION of this NOA will occur after the expiration date or if there has been a revision or change in the materials, use, and/or manufacture of the product or process. Misuse of this NOA as an endorsement of any product, for sales, advertising or any other purposes shall automatically terminate this NOA. Failure to comply with any section of this NOA shall be cause for termination and removal of NOA.

ADVERTISEMENT: The NOA number preceded by the words Miami-Dade County, Florida, and followed by the expiration date may be displayed in advertising literature. If any portion of the NOA is displayed, then it shall be done in its entirety.

INSPECTION: A copy of this entire NOA shall be provided to the user by the manufacturer or its distributors and shall be available for inspection at the job site at the request of the Building Official.

This NOA revises NOA #17-0802.13 and consists of this page 1, evidence submitted pages E-1, E-2 & E-3 as well as approval document mentioned above.

The submitted documentation was reviewed by **Helmy A. Makar, P.E., M.S.**



Helmy A. Makar
02/18/2021

NOA No. 20-1102.05
Expiration Date: 09/13/2022
Approval Date: 02/18/2021
Page 1

NOTICE OF ACCEPTANCE: EVIDENCE SUBMITTED

1. EVIDENCE SUBMITTED UNDER PREVIOUS APPROVAL #08-0826.04

A. DRAWINGS

1. *Drawing #1597, titled "Maxima, 24 Gage Structural Galvalume Steel Roof System", sheets 1 through 4 of 4, dated July 31, 2008, prepared, signed and sealed by Bala Sockalingam, P.E., on October 29, 2008.*

B. TESTS

1. *Test reports on 1) Uniform Static Air Pressure Test, Loading per ASTM E1592 and 2) Large Missile Impact Test per TAS 201 along with marked-up drawings and installation diagram 24 GA 16" steel roof panel, prepared by Hurricane Test Laboratory, Inc., Test Report No. 0420-0216-06 and 0420-0313-06, dated 05/25/2006, signed and sealed by Vinu J. Abraham, P.E.*
2. *Test reports on 1) Wind and Wind Driven Rain Resistance of Discontinuous Roof Systems, TAS 100-95 along with marked-up drawings and installation diagram 24 GA 16" steel roof panel, prepared by Asphalt Technologies, Inc., Test Report No. NBS-002-02-01, dated 03/30/2006, signed and sealed by Charles L. Thomas, P.E.*
3. *Test reports on 1) Uniform Static Air Pressure Test, Loading per ASTM E1592 along with marked-up drawings and installation diagram 24 GA 16" steel roof panel, prepared by Hurricane Test Laboratory, Inc., Test Report No. 0420-0610-07, dated 07/12/2007, signed and sealed by Vinu J. Abraham, P.E.*
4. *Accelerated weathering per ASTM G153.*
5. *Test Report for Suseptability to Leakage for roof system assemblies per TAS-114, dated 04/03/2006, signed and sealed by Charles L. Thomas, P.E.*
6. *Salt Spray test per ASTM B117.*

C. CALCULATIONS

1. *Fasteners Calculations and structural analysis, prepared by Bala Sockalingam, P.E., dated 07/07/2006, signed and sealed by Bala Sockalingam, P.E.*
2. *Fasteners Calculations and structural analysis, prepared by Bala Sockalingam, P.E., dated 07/24/2007, signed and sealed by Bala Sockalingam, P.E.*

D. QUALITY ASSURANCE

1. *By Miami-Dade County Building Code Compliance Office.*

E. MATERIAL CERTIFICATION

1. *Mill Certificate, prepared by Wheeling Nisshin, dated 01/09/2006.*
2. *Tensile Test prepared by QC Metallurgical, Inc., Project No. 6FM-501, dated 06/19/2006, for steel samples, tested per ASTM E8-00, signed and sealed by Frank Grate, P.E.*

F. OTHERS

1. *Private Labeling agreement with Manufacturer of NOA # 06-0803.04*



Helmy A. Makar, P.E., M.S.
Product Control Section Supervisor
NOA No. 20-1102.05
Expiration Date: 09/13/2022
Approval Date: 02/18/2021

NOTICE OF ACCEPTANCE: EVIDENCE SUBMITTED

2. EVIDENCE SUBMITTED UNDER PREVIOUS APPROVAL # 09-0715.01

A. DRAWINGS

1. *Drawing #1597, titled "Maxima, 24 Gage Structural Galvalume Steel Roof System", sheets 1 through 4 of 4, dated July 31, 2008, last revision #1 dated June 22, 2009, prepared, signed and sealed by Bala Sockalingam, P.E., on June 22, 2009.*

B. TESTS

1. *None.*

C. CALCULATIONS

1. *None.*

D. QUALITY ASSURANCE

1. *By Miami-Dade County Building Code Compliance Office.*

E. MATERIAL CERTIFICATION

1. *None.*

3. EVIDENCE SUBMITTED UNDER PREVIOUS APPROVAL # 12-0831.02

A. DRAWINGS

1. *Drawing #1597, titled "Maxima, 24 Gage Structural Galvalume Steel Roof System", sheets 1 through 4 of 4, dated July 31, 2008, last revision #2 dated August 10, 2012, prepared, signed and sealed by Bala Sockalingam, P.E.*

B. TESTS

1. *None.*

C. CALCULATIONS

1. *None.*

D. QUALITY ASSURANCE

1. *By Miami-Dade County Department of Regulatory and Economic Resources.*

E. MATERIAL CERTIFICATION

1. *None.*

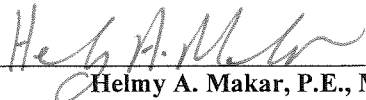

Helmy A. Makar, P.E., M.S.
Product Control Section Supervisor
NOA No. 20-1102.05
Expiration Date: 09/13/2022
Approval Date: 02/18/2021

NOTICE OF ACCEPTANCE: EVIDENCE SUBMITTED

4. EVIDENCE SUBMITTED UNDER PREVIOUS APPROVAL # 17-0802.13

A. DRAWINGS

1. *Drawing #1597, titled "Maxima, 24 Gage Structural Galvalume Steel Roof System", sheets 1 through 4 of 4, dated July 31, 2008, last revision #3 dated July 07, 2017, prepared, signed and sealed by Bala Sockalingam, P.E.*

B. TESTS

1. *None.*

C. CALCULATIONS

1. *None.*

D. QUALITY ASSURANCE

1. *By Miami-Dade County Department of Regulatory and Economic Resources.*

E. MATERIAL CERTIFICATION

1. *None.*

F. OTHERS

1. *FBC, 2014 and 2017 Editions compliance letter, dated July 10, 2017, prepared, signed and sealed by Bala Sockalingam, P.E.*

5. NEW EVIDENCE SUBMITTED

A. DRAWINGS

1. *Drawing #1597, titled "Maxima, 24 Gage Structural Galvalume Steel Roof System", sheets 1 through 4 of 4, dated July 31, 2008, last revision #4 dated 10/01/2020, prepared, signed and sealed by Bala Sockalingam, P.E.*

B. TESTS

1. *None.*

C. CALCULATIONS

1. *None.*

D. QUALITY ASSURANCE

1. *By Miami-Dade County Department of Regulatory and Economic Resources.*

E. MATERIAL CERTIFICATION

1. *None.*

F. OTHERS

1. *FBC, 2020 Edition compliance letter, dated October 07, 2020, prepared, signed and sealed by Bala Sockalingam, P.E.*



Helmy A. Makar, P.E., M.S.
Product Control Section Supervisor
NOA No. 20-1102.05
Expiration Date: 09/13/2022
Approval Date: 02/18/2021

DRAWN BY:	B.S.	CHECKED BY:	T.J.
DATE:	6.22.09	DATE:	7/31/08
REVISION NO.	DATE	BY	DESCRIPTION
1	8.10.12	BS	REVISE NOTE 7.
2	7.7.17	BS	REVISE NOTE 1.
3	10.1.20	BS	REVISE NOTE 1.
4		BS	REVISE NOTE 1.

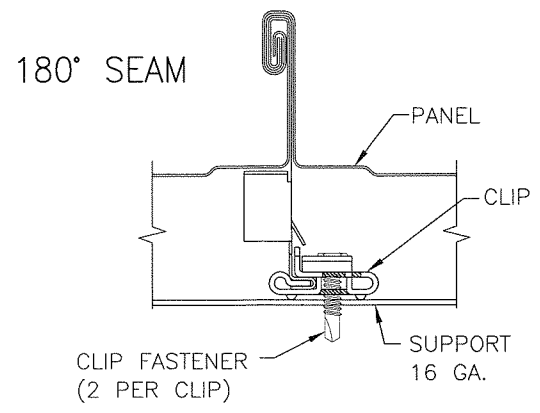
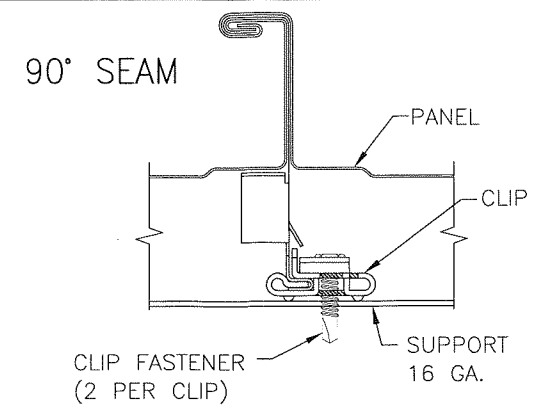
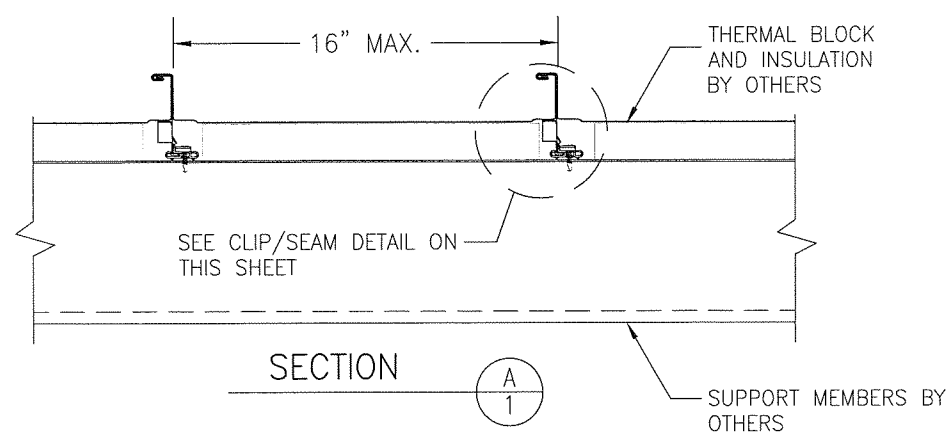

GENERAL NOTES:

- THIS STRUCTURAL ROOF PANEL SYSTEM HAS BEEN DESIGNED IN ACCORDANCE WITH 2020 FLORIDA BUILDING CODE (F.B.C.). THE DESIGN PRESSURES AS DETERMINED FROM SECTION 1620 AND ASCE 7-16 MUST BE MULTIPLIED BY 0.6.
- ROOF PANELS ARE FABRICATED FROM A MAX. 22.25" WIDE COIL & SHALL BE 24 GA. ($t = 0.0245$ ") ASTM 792 GRADE D STEEL WITH A SILICONIZED POLYESTER COATING APPLIED. EFFECTIVE COVERING WIDTH OF PANEL = MAX. 16". $F_y = 56.4$ ksi (MIN.)
- THE ROOF PANELS SHALL BE INSTALLED OVER ROOF STRUCTURE AS SPECIFIED ON THESE DRAWINGS.
- PANEL END OVERLAPS MAY OCCUR WITHIN 12" OF SUPPORTING PURLIN WEB PROVIDING THE END LAPS ARE CONSTRUCTED, SUPPORTED & SEALED PER THE END LAP DETAIL ON SHEET 3.
- REQUIRED DESIGN WIND LOADS SHALL BE DETERMINED FOR EACH PROJECT.
- THIS ROOFING PANEL SYSTEM HAS BEEN TESTED IN ACCORDANCE WITH FLORIDA BUILDING CODE:
 - * ACCELERATED TESTING OF COATING PER ASTM G153
 - * SALT SPRAY TESTING PER ASTM B117
 - * UPLIFT RESISTANCE TEST PER TAS-125 & ASTM E1592
 - * WIND DRIVEN RAIN & STANDING WATER TESTS PER TAS-100 & TAS-114
 - * TENSILE TESTS PER ASTM E8
- ROOF PANEL MANUFACTURER'S PERMANENT LABEL SHALL BE PLACED AT THE END OF EACH PANEL RUN AND SHALL READ: MCELROY METAL, INC. CLINTON, IL. & PEACHTREE CITY, GA. MIAMI-DADE COUNTY PRODUCT CONTROL APPROVED
- ALL SCREWS SHALL BE CORROSION RESISTANT SELF DRILLING SCREWS.
- THE SUPPORTING STRUCTURE, OVER WHICH THE PANELS ARE TO BE INSTALLED, MUST BE MINIMUM 16 GAGE (MIN. 0.0598") STEEL WITH MIN. $F_y = 50$ KSI.
- MAXIMUM POSITIVE AND NEGATIVE DESIGN LOADS FOR 24 GA. MAXIMA WITH 90° OR 180° SEAM IN THE ROOF FIELD, PERIMETER AND CORNER ZONES SHALL BE THE LOWEST DESIGN LOAD CALCULATED BASED ON THE PANEL ALLOWABLES AND CLIP TYPE SHOWN. MAXIMUM ALLOWABLE DEFLECTION LIMIT = $L/240$.

PANEL ALLOWABLES	FOR POSITIVE LOAD *	FOR UPLIFT LOAD *	
	ALL SEAM TYPES	90° SEAM	180° SEAM
M (SUPPORT) (lb.ft/ft)	125	86	111
M (SPAN) (lb.ft/ft)	100	69	89
REACTION (lb/ft)	275	189	244
EI (lb.in ³ /ft)	4074248	1654505	2246583

* SEE NOTE 10.

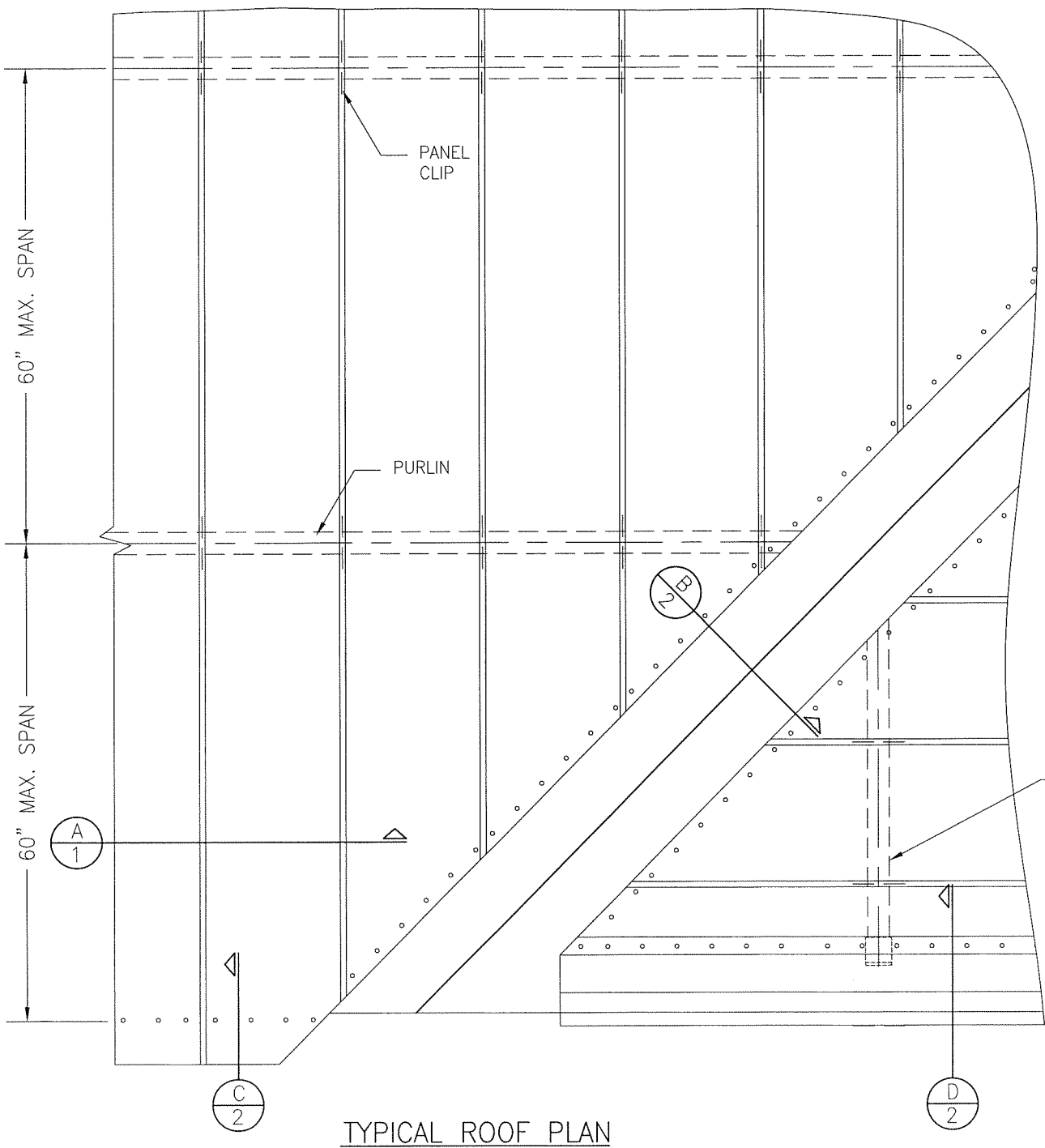

PURLINS AT MAX. 5'-0" O.C. BY OTHERS (MIN. 16 GA. STEEL MEMBER REQUIRED PER GENERAL NOTE #9)

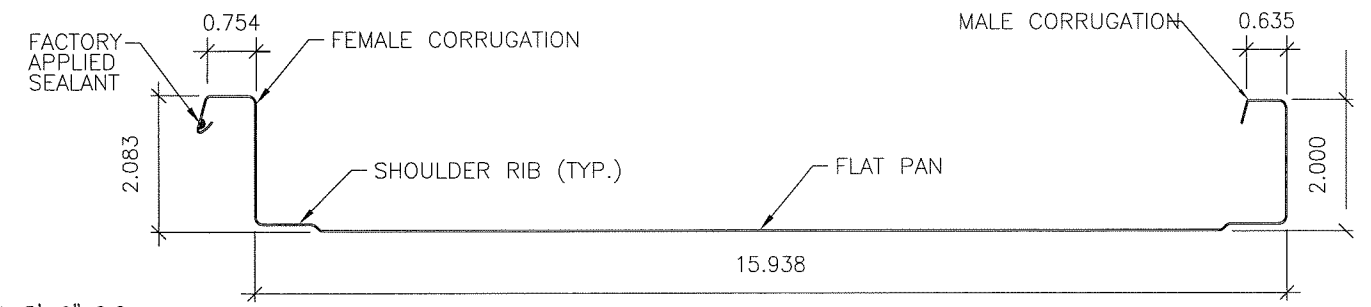

24 GA. GALVALUME COATED STEEL WITH PAINTED FINISH ($t = 0.0245$ " MIN.)

PRODUCT APPROVAL IS LIMITED TO THE ROOF PANEL & ITS CONNECTING CLIPS. THE STRUCTURAL ADEQUACY OF ALL OTHER STRUCTURAL ITEMS (BEAMS, COLUMNS, PURLINS, FACIA SUPPORTS, CONNECTIONS OF STRUCTURE, ETC.) SHALL BE VERIFIED BY THE STRUCTURAL PLANS EXAMINER OF THE CORRESPONDING BUILDING DEPARTMENT. THE METAL ROOF PANELS SHALL NOT BE DESIGNED TO ACT AS A DIAPHRAGM.

PRODUCT REVISED as complying with the Florida Building Code
 Acceptance No 20-1102.05
 Expiration Date 09/13/2022
 By *[Signature]*
 Miami Dade Product Control

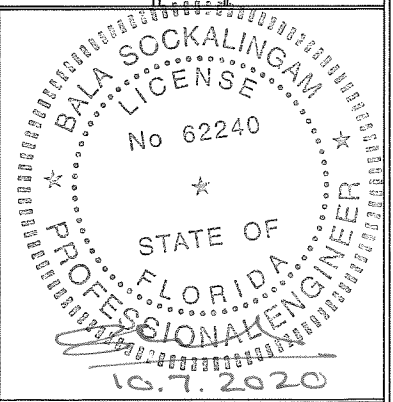

DRAWING TITLE: MAXIMA, 24 GAGE STRUCTURAL GALVALUME STEEL ROOF SYSTEM

MANUFACTURER: MCELROY METAL, INC. 1500 HAMILTON RD. BOSSIER CITY, LA 71111 800-950-6531

CONSULTANTS: BALA SOCKALINGAM, PH.D., P.E. 1216 N LANSING AVE, SUITE C TULSA, OK 74106 PHONE: 918-492-5992 FAX: 866-366-1543

NO.	REVISION DESCRIPTION	BY	DATE

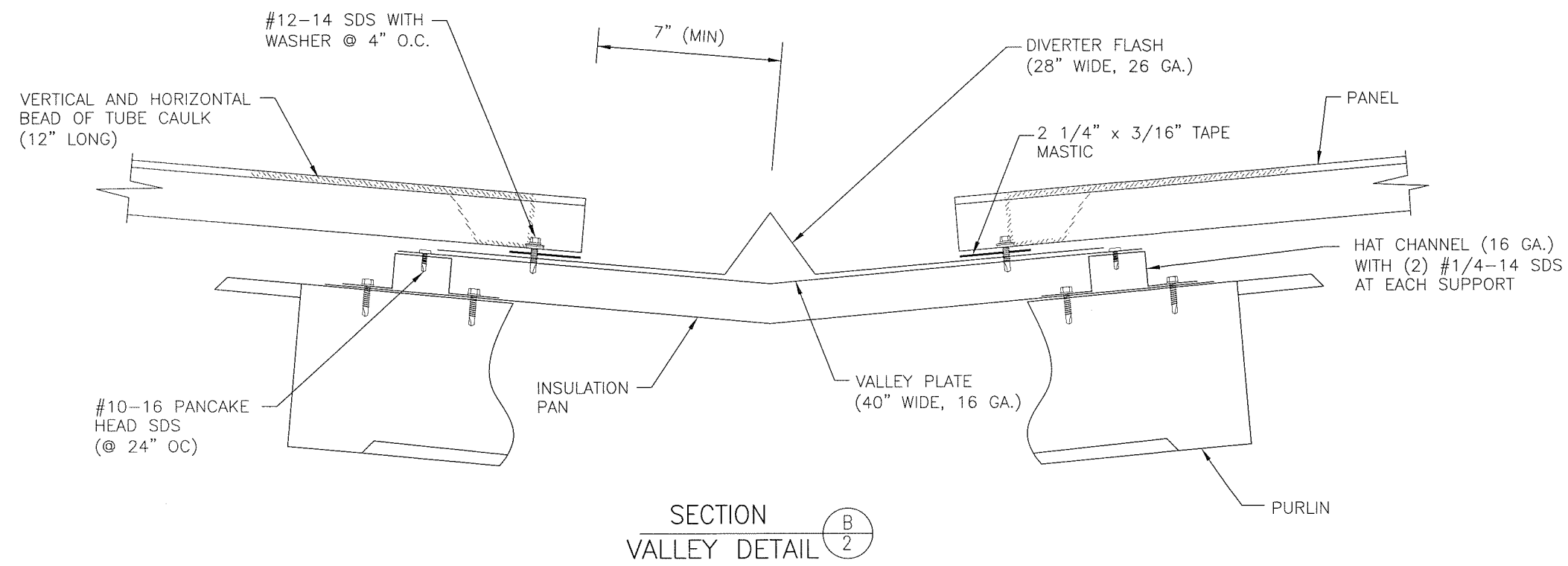

SECTION
VALLEY DETAIL (B/2)

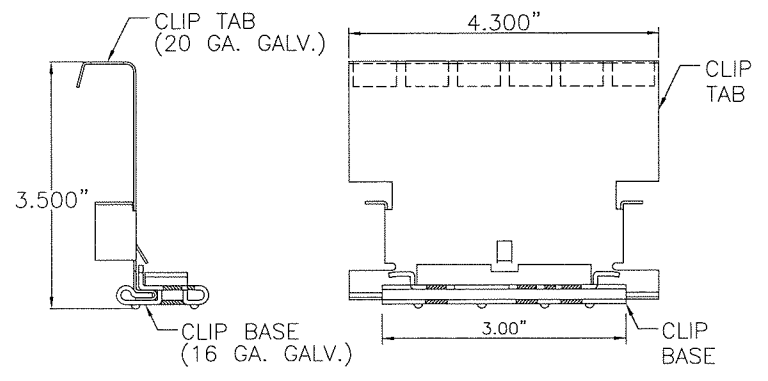

MC 1213
USED WITH 6\"/>

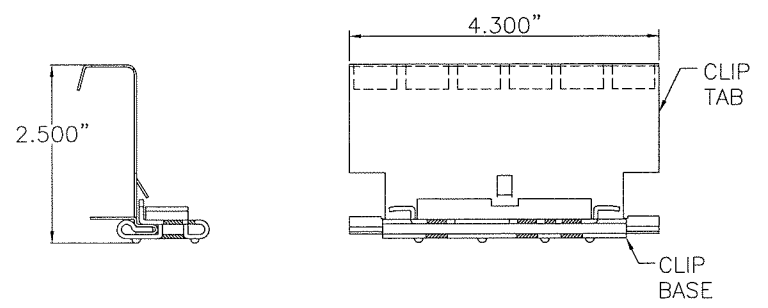

MC 1203
USED WITH 4\"/>

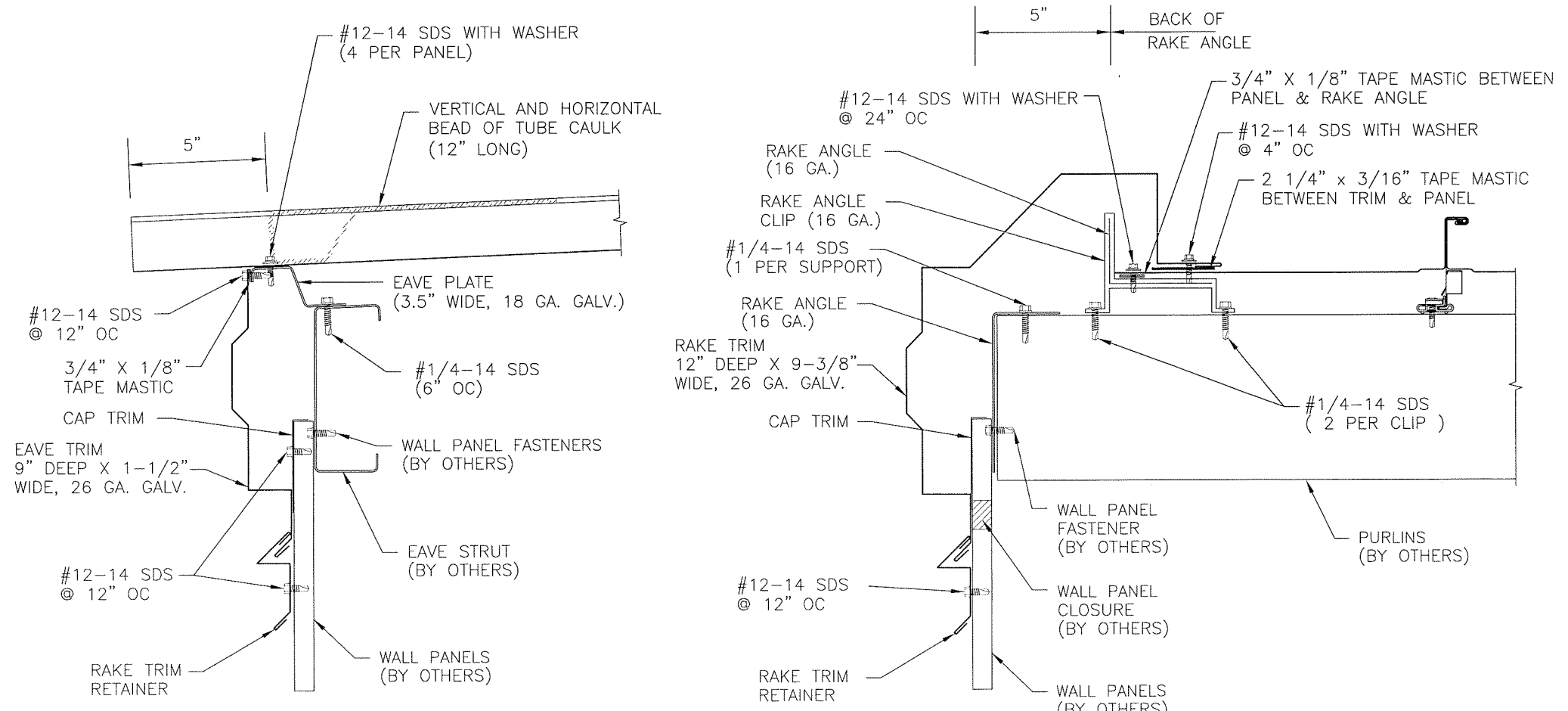

SECTION
EAVE DETAIL (C/2)

SECTION
RAKE DETAIL (D/2)

NOTE: ALL FLASHING MATERIAL NOT CALLED OUT WITH A SPECIFIC GAGE THICKNESS SHALL BE MIN. 26 GAGE.

PRODUCT REVISED
as complying with the Florida
Building Code
Acceptance No. 20-1102.05
Expiration Date 09/13/2022
By *Heidi A. Miller*
Miami Design Product Control

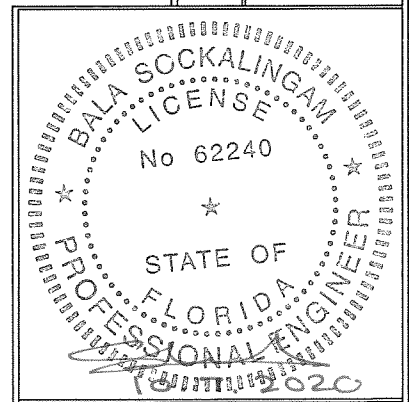

DRAWING TITLE
MAXIMA, 24 GAGE STRUCTURAL GALVALUME STEEL ROOF SYSTEM

MANUFACTURER
MCELROY METAL, INC.
1500 HAMILTON RD.
BOSSIER CITY, LA 71111
800-950-6531

CONSULTANTS
BALA SOCKALINGAM, PH.D., P.E.
6717 S. YALE AVE, SUITE 200
TULSA, OK 74136
PHONE: 918-492-5992 FAX: 918-493-3568

DATE	BY	REVISION DESCRIPTION	NO.

DRAWING TITLE
MAXIMA, 24 GAGE STRUCTURAL GALVALUME STEEL ROOF SYSTEM

MANUFACTURER
MCELROY METAL, INC.
 1500 HAMILTON RD.
 BOSSIER CITY, LA 71111
 800-950-6531

CONSULTANTS
BALA SOCKALINGAM, PH.D., P.E.
 6717 S. YALE AVE, SUITE 200
 TULSA, OK 74136
 PHONE: 918-492-5992 FAX: 918-493-3568

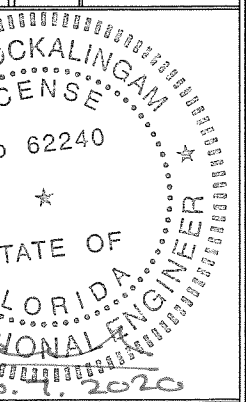

DRAWING NO.	REV.	SHEET NO.
1597	D	3 OF 4

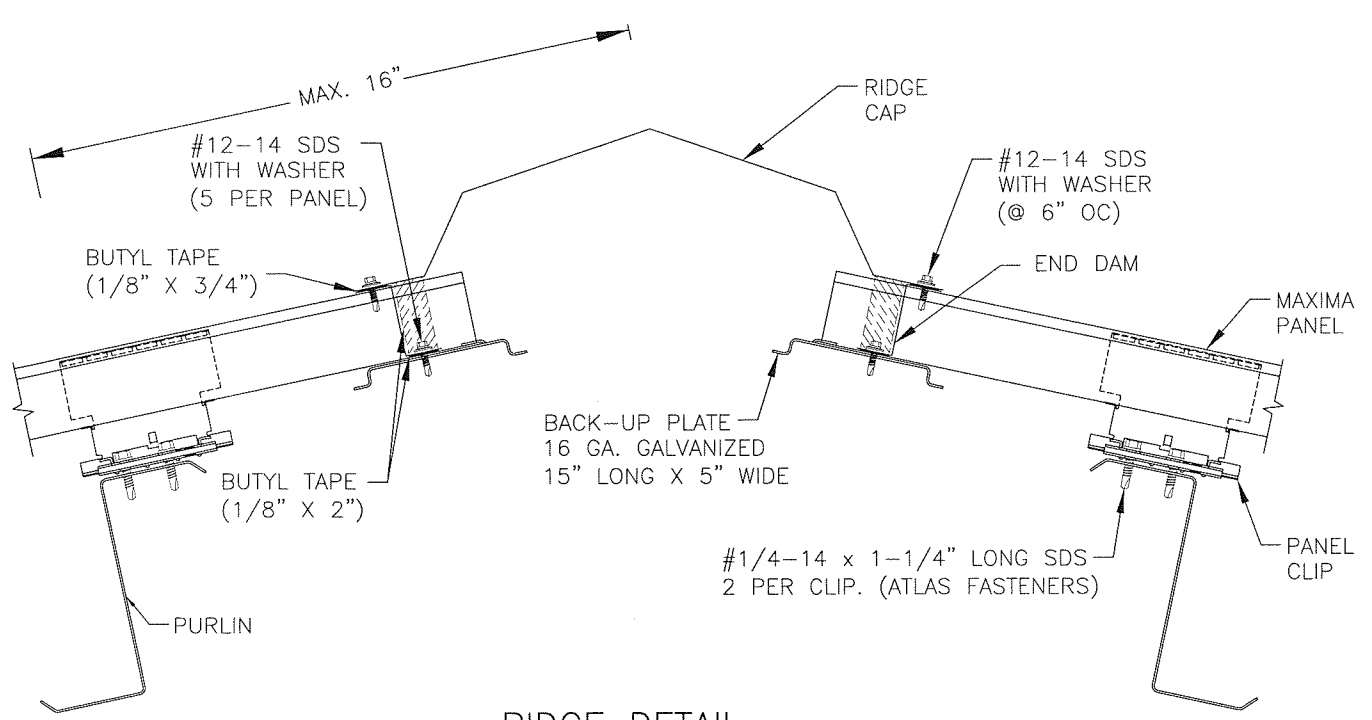

RIDGE DETAIL

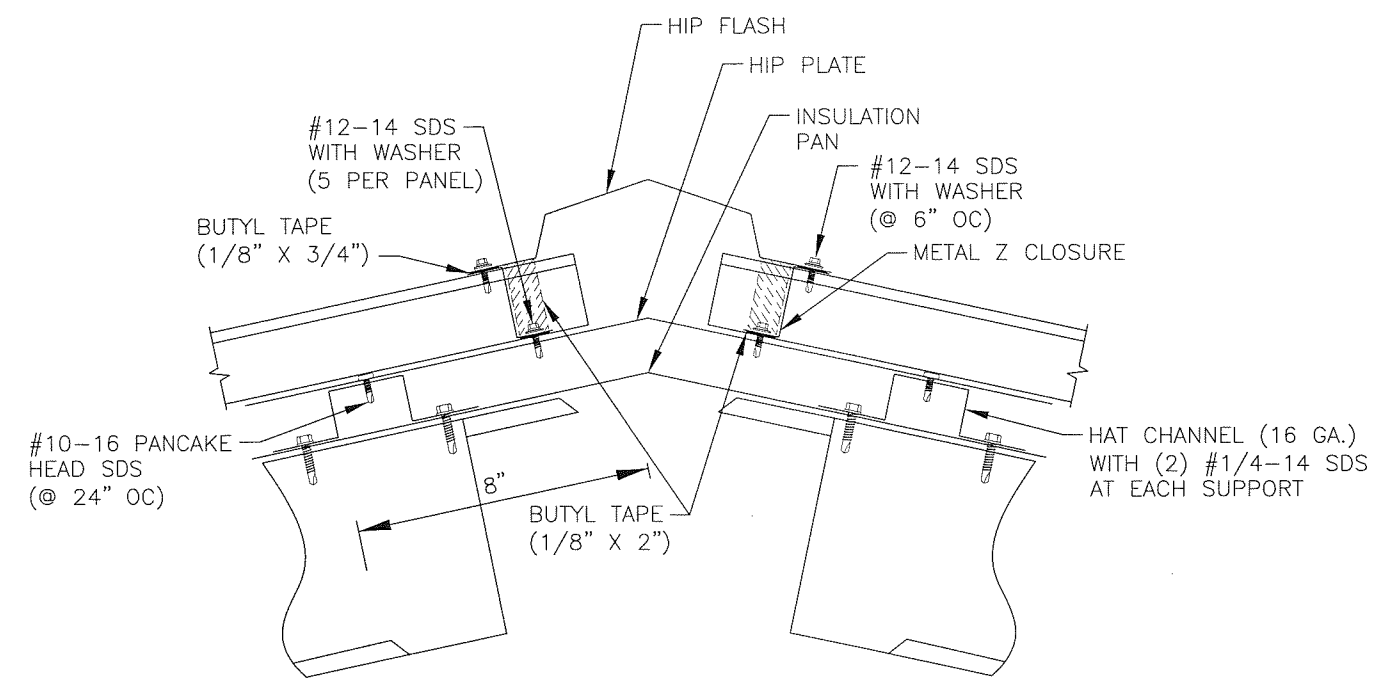

HIP DETAIL

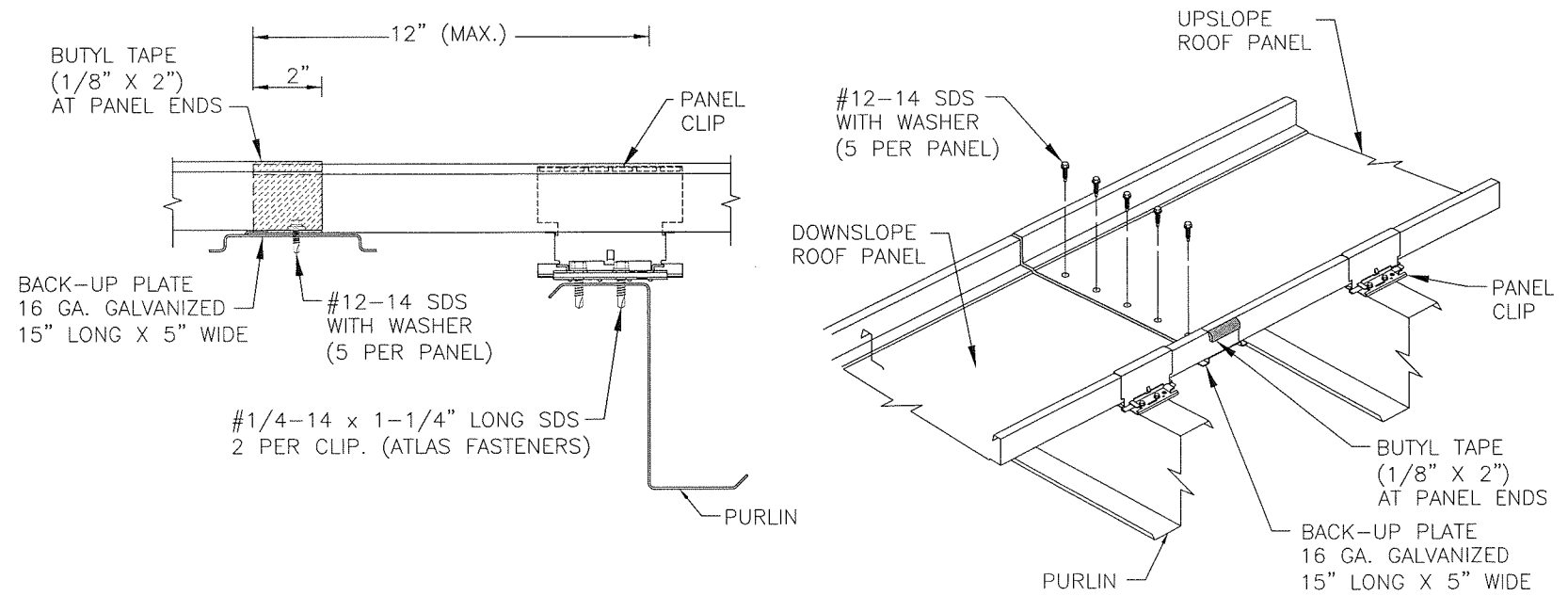

END LAP DETAILS

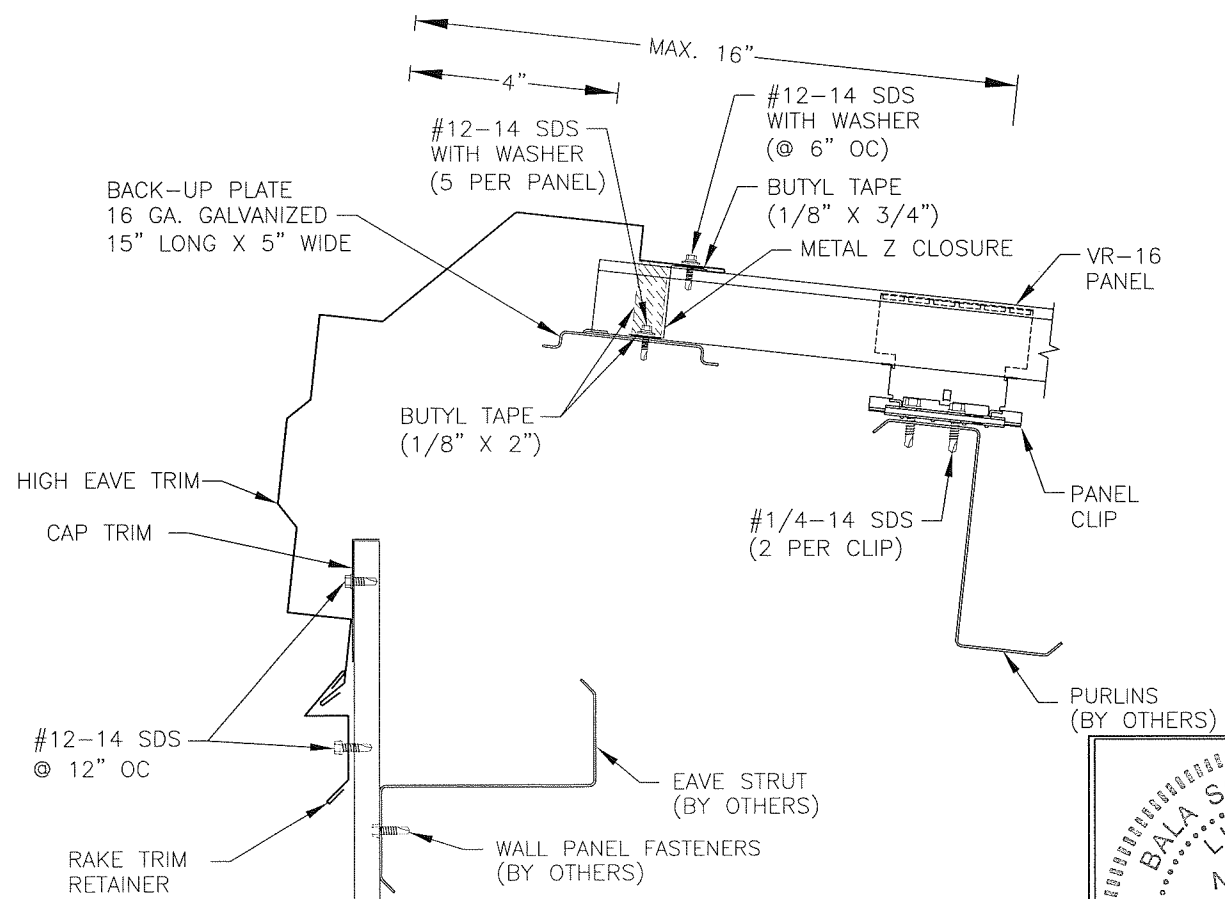

HIGH EAVE DETAIL

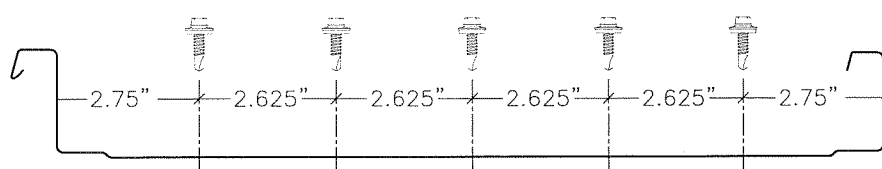

FASTENER PATTERN AT ENLAP

NOTE: ALL FLASHING MATERIAL NOT CALLED OUT WITH A SPECIFIC GAGE THICKNESS SHALL BE MIN. 26 GAGE.

PRODUCT REVISED
 as complying with the Florida
 Building Code
 Acceptance No. 20-1107.05
 Expiration Date 09/13/2022
 By He G.A. Walker
 Manual Dept Product Control

DRAWN BY:	B.S.	CHECKED BY:	T.J.
PLOT:		DATE:	7/31/08
NO.		REVISION DESCRIPTION	
BY		DATE	

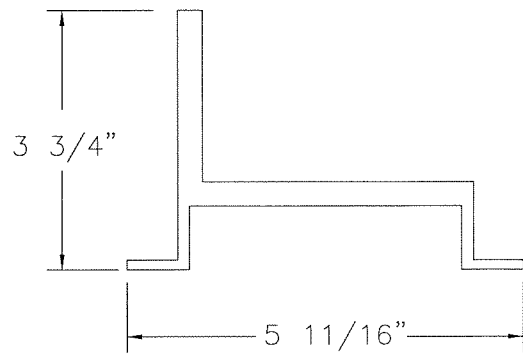

RAKE ANGLE CLIP
(16 GA. GALV.)

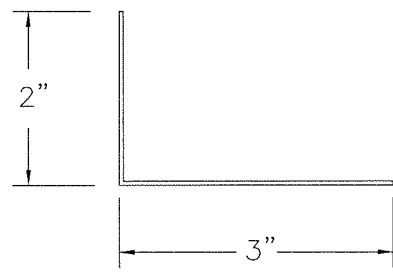

RAKE ANGLE
(16 GA. GALV.)

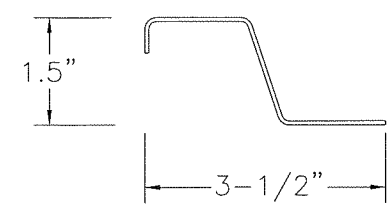

EAVE PLATE
(18 GA. GALV.)

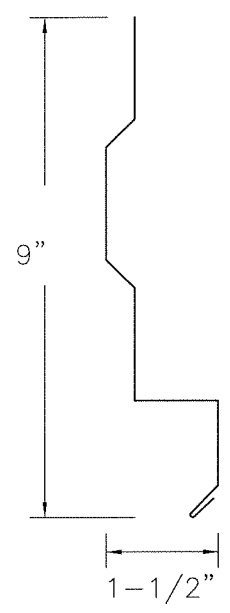

EAVE TRIM
(26 GA.)

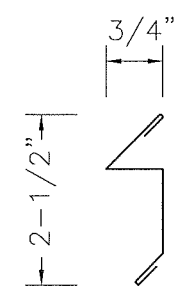

RAKE RETAINER TRIM
(26 GA.)

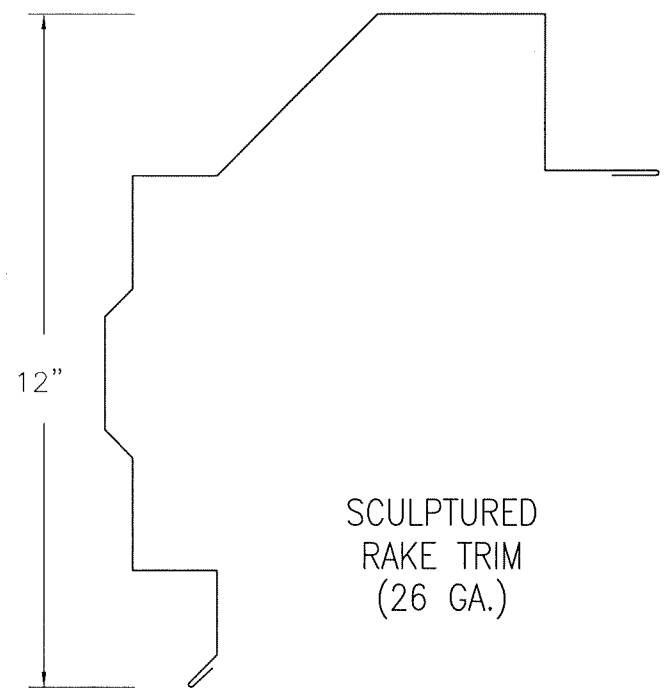

SCULPTURED RAKE TRIM
(26 GA.)

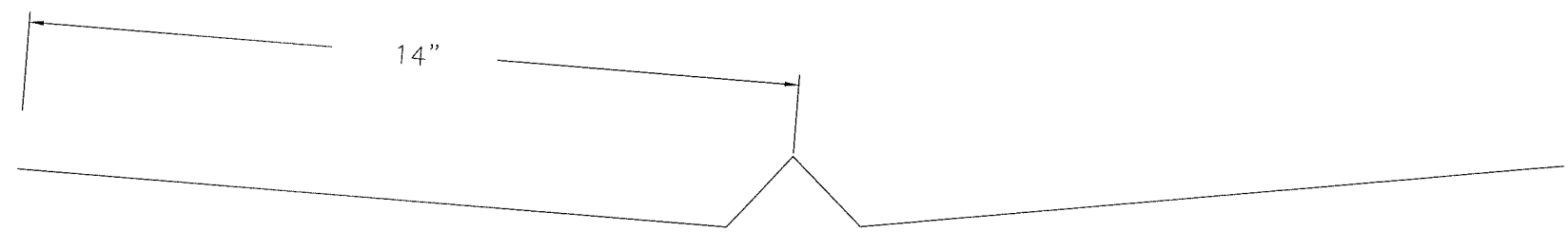

DIVERTER FLASH
(26 GA.)

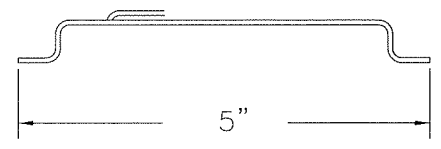

BACK-UP PLATE
(16 GA. GALV.)

DRAWING TITLE
MAXIMA, 24 GAGE STRUCTURAL GALVALUME STEEL ROOF SYSTEM

MANUFACTURER
MCELROY METAL, INC.
1500 HAMILTON RD.
BOSSIER CITY, LA 71111
800-950-6531

CONSULTANTS
BALA SOCKALINGAM, PH.D., P.E.
6717 S. YALE AVE., SUITE 200
TULSA, OK 74136
PHONE: 918-492-5992 FAX: 918-493-3568

ALL FLASHING MATERIAL -
ALUMINUM/ZINC COATED STEEL

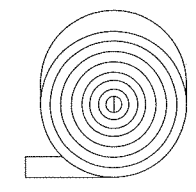

TAPE SEALANT
(3/4"x1/8"x50') Butyl
(2-1/4"x3/16"x20') Butyl
(2"x1/8"x22") Butyl

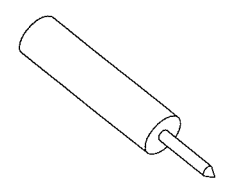

TUBE SEALANT



CLIP FASTENER
1/4-14 SDS
1-1/4" LONG

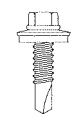

FLASHING/PERIMETER FASTENER
12-14 SDS WITH WASHER
1-1/4" LONG

PRODUCT REVISED
as complying with the Florida
Building Code
Acceptance No. 20-1102.05
Expiration Date 09/13/2022
By *Healy A. Mohr*
Miami Data Product Control

