



TECHNICAL BULLETIN

Issue Date: September 9, 2002

No. 03-143-02

UL Construction #308

Medallion II

UL580 Class 90 Wind Uplift

1. **Metal Roof Deck Panels*** - 24 MSG min coated steel. Max panel width 16-1/2 in. and rib height 1-1/2 in. End laps to occur adjacent to supports with panels overlapped 4 in. min.
McElroy Metal Mill, Inc. "Medallion"
- 1B. **Metal Rood Deck Panels* (Battens)** – Battens covering panel ribs and clips to be 2 in. wide and 2 in. high, formed from same type and thickness material as that used to fabricate metal panels (Item 1).
McElroy Metal Mill, Inc. "Medallion II Batten"
2. **Roof Deck Fasteners* - (Panel Clips)** – One piece clip, 1-3/4 in. high, 1 in. wide by 2 in. long. Clips are spaced max 24 in. OC and located at panel sides. Guide holes in bottom of clip to accommodate screw fasteners (Item 3).
McElroy Metal Mill, Inc. "Medallion II"
3. **Fasteners** – Screws used to attach plywood or OSB substructure (Item 4) to metal deck to be #14 type Phillips head. Fastener length to penetrate metal deck (Item 6) min of 1/2". Spacing to be 6" OC at plywood or OSB ends and 12" OC at 2'-0" pattern down length of plywood or OSB. (Total of 33 fasteners per 4 by 8 ft sheet). Screws used to attach panel clips (Item 2) to plywood or OSB to be #10 by 1" long pancake head wood screw with #2 Phillips head size, or #10 by 1" long hex head wood screw. One screw per clip. (Alternate – When bearing plates replace Item 4A). Screws used to attach panel clips (Item 2) through bearing plate (Item 4) into metal deck to be #14 type with Phillips head. Fastener length to penetrate metal deck (Item 6) min of 1/2". One screw per clip. An optional #10 by 1" self-drilling fastener may be used to attach clip (Item 2) to the bearing plate (Item 4) when installer chooses to install rigid board insulation and use bearing plate to hold it in place until clips and panels are installed.
4. **Substructure** – Bearing plates – (Optional) – To be used in lieu of plywood or OSB (Item 4, 4A) with rigid insulation (Item 5) up to a max thickness of 6 in. Bearing plates to be 16 MSG min coated steel. Located under each clip (Item 2) for support.
- 4A. **Plywood or OSB** – (Optional) – Min APA Rated plywood, exposure sheathing span C-D 40/20, nom 1/2 in. thick or oriented strand board (OSB), nom 7/16 in. thick, 4 x 8 ft. Sheets to be installed on top of Rigid Insulation (Item 5) in lieu of bearing plates (Item 4A). To be used with Rigid Insulation (Item 5), max thickness 4 in.
5. **Rigid Insulation** – (Optional) – Foamed plastic, max thickness 4 in. when plywood or OSB (Item 4, 4A) is used and 6 in. when bearing plates (Item 4) are used. Compressive strength to be 2 PCF.
- 5A. **Gypsum Board** – (Optional) – (Not Shown) Any 5/8" thick gypsum wallboard supplied in sheets 2' x 4' to 4' x 12', applied perpendicular to steel deck direction with adhesive. End joints to occur over crests of steel roof deck and be staggered 2' in adjacent rows. The total cumulative thickness of the rigid board (Item 5) and gypsum board may not exceed total thicknesses shown under Item 5.
- 5B. **Waterproof Membrane** – (Optional) – (Not Shown) – Used to protect plywood or OSB (Item 4A). Installed under panels (Item 1).
- 5C. **Vapor Barrier** – (Optional) – (Not Shown) – Installed on top of metal deck (Item 6) or on top of gypsum wallboard (Item 5A) if used. Min. 6 mil plastic sheet.
6. **Metal Deck** – 22 MSG min coated steel. Min depth 1-1/2 in. with ribs at 6 in. OC. End lap to be 4 in. min and occur over purlin. Metal deck to be welded to purlin in every other low flute, except for end laps which are welded in every low flute.
7. **Purlin** – No. 14 MSG min steel (55,000 psi min yield strength).

Refer to General Information, Roof Deck Construction, (Roofing Materials and Systems Directory) for Items Not Evaluated.

*Bearing the UL Classification Mark

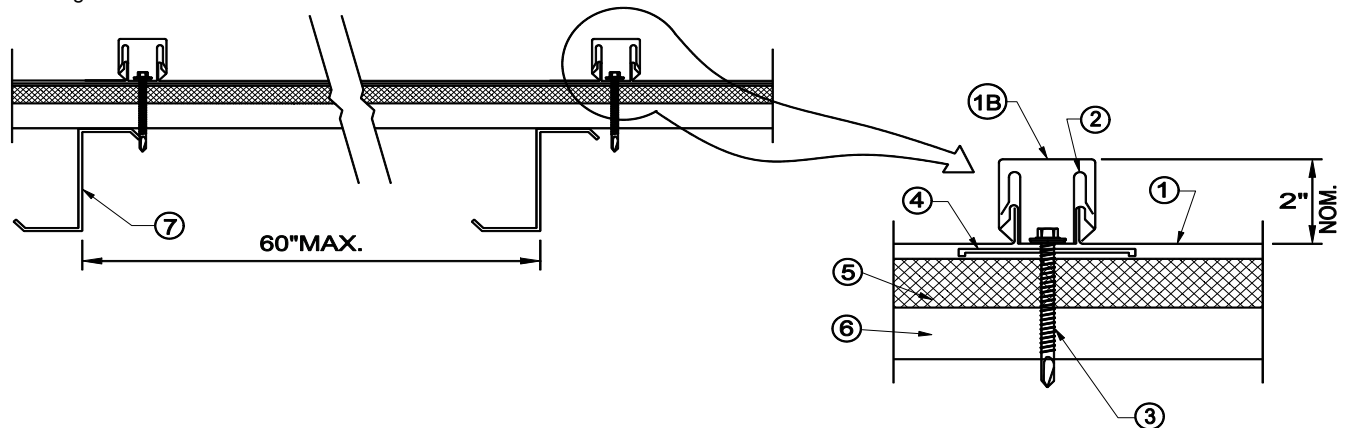

CORPORATE OFFICE
SHREVEPORT, LOUISIANA