



TECHNICAL BULLETIN

Issue Date: September 9, 2002

Revised: June 1, 2006

No. 03-148-02

UL Construction #506A

Maxima, Maxima ADV

UL580 Class 90 Wind Uplift

1. **Metal Roof Deck Panels*** - No. 24 MSG min coated steel. Max panel width 18in.; min 12 in. Rib height 2 in. Panels continuous over three or more clips (Item 2). The panel flat area may have optional striated or minor ribs placed at various locations in the panel flat area beginning min of 2 in. from side ribs. The upper flange of the panel rib may be horizontal, or optionally formed down to produce angle of 0 degree to 90 degree between the vertical segment and the top flange of the rib. Panel end lap 2 in. min. An end lap back-up plate (Item 2A) to be used at panel end lap. A bead of sealant may be used at panel end lap and side ribs. Ribs to be seamed with an electric or hand seaming tool to form a flange with a tight hem. Seaming process to include the upper portion of the panel clips (Item 2).
McElroy Metal Mill, Inc. "Maxima-212", "Maxima-216", "Maxima-218"
- 1A. **Metal Roof Deck Panels*** - (Not Shown) – Panels (coated steel only) may be physically or mechanically curved at a radius of 4 ft. or greater.
McElroy Metal Mill, Inc. "Maxima ADV"
2. **Roof Deck Fasteners* - (Panel Clips)** – Located at side of panels (Item 1) over substructure (Item 3, 3A, 3B or 3C) and fastened through substructure to liner panel (Item 8) with max spacing of 48 in. OC or over sub-purlins (Item 7) with max spacing of 48 in. OC; or when panel clips are fastened directly to plywood (Item 3B) as described in Item 6B, max spacing to be 36 in. OC.
Fixed Clip (Not Shown) – One piece assembly fabricated from No. 22 MSG min thick steel, 3-1/2 in. wide.
McElroy Metal Mill, Inc. "Maxima Fixed Clip"
Floating Clip – Two piece assembly with a base fabricated from No. 16 MSG min thick steel, 2" wide and a tab fabricated from No. 22 MSG min thick steel, 4-1/4 in. wide.
McElroy Metal Mill, Inc. "Maximum Floating Fixed Clip"
- 2A. **End Lap Back-Up-Plate-** (Not Shown) – No. 16 MSG min thick coated steel channel, 3 in. wide with two 3/8 in. deep legs. Max length 74 in. Located under the panel (Item 1) end lap (50 ksi min yield strength).
- 2B. **End Lap Back-Up-Plate** – (Optional) – (Not Shown) – No. 16 MSG min thick coated steel. Width 11,15 or 17 in., length 7 in. Two 3/4 in. by 3/4 in. tabs and a 1 in. deep vertical leg located at upslope edge of panel (50 ksi min yield strength).
- 2C. **Roof Deck Fasteners*(Cinch Plate)** – (Optional) – (Not Shown) – width 1-5/16". Length 18" max. Fabricated from No. 20 MSG min thick stainless steel. Located over end lap.
3. **Substructure – (Gypsum Board)** – (Opt.) – Min thick 1/2" To be placed on top of either the liner panel (Item 8) or rigid insulation (Item 5). Combined thickness of the gypsum board and rigid insulation not to exceed 4 in. All joints to be taped with 2.5 in. wide joint tape.
- 3A. **Substructure – (Plywood)** – (Opt.) – (Not Shown) – Plywood decking used in lieu of gypsum board (Item 3), to be nom 1/2" thick, exposure 1 sheathing, 40/20, CD. Located over rigid insulation (Item 5). Combined thickness of the plywood and rigid insulation not to exceed 4 in.
- 3B. **Substructure – (OSB)** – (Optional) – (Not Shown) – OSB decking, used in lieu of gypsum board (Item 3), to be nom 1/2 in. thick. Located over rigid insulation (Item 5). Combined thickness of the OSB and rigid insulation not to exceed 4 in.
- 3C. **Substructure – (Bearing Plate)** – (Optional) – Bearing Plate to be used in lieu of gypsum board (Item 3) to be 4 by 4 in by No. 18 MSG min thick coated steel (33 ksi min yield strength). Used under each clip (Item 2) over rigid insulation (Item 5) only when rigid insulation is located directly under panel (Item 1).
4. **Vapor Barrier** – (Optional) – Single ply, used between the substructure (Items 3, 3A or 3B) and panel (Item 1). To be min 30 lb roofing felt.
5. **Foamed Plastic – (Rigid Insulation)** (Optional) – Max thickness 3-1/2 in. when gypsum board (Item 3), plywood (Item 3A) or OSB (Item 3B) is used and 10 in. when bearing plates (Item 3C) are used. Min bearing strength to be 20 psi. 1.8 pcf min density or see products classified under TJBX.
- 5A. **Insulation** – (Optional) – Compressible blanket insulation 8 in. max thickness before compression. Used with sub-purlins (Item 7) only.
6. **Fasteners – (Screws)** – Fasteners used to attach panel clips (Item 2) to sub-purlins (Item 7) to be No. 1/4-14 by 1 in. long self-drilling, self-tapping, hex-washer-head, plated steel screws. Two fasteners per clip. Fasteners used at end lap of panel (Item 1) to be one of the following: No.1/4-14 by 1 in. long, Type AB point self-drilling, self-tapping, hex-washer-head, plated or stainless steel screws or No. 12-14 by 1-14 in. long self-drilling, self-tapping, hex-washer-head, plated steel screws. Spacing for 12 in. wide panel to be 1,3,4,4,3,1 in. pattern. Spacing for 16 in. wide panels to be 1,3,4,4,3,1 in. pattern; spacing for 18 in. wide panels to be 1-1/2, 3-1/2, 4, 4, 3-1/2, 1-1/2 in. pattern.

CORPORATE OFFICE
SHREVEPORT, LOUISIANA



- 6A. **Fasteners – (Screws)** – Fasteners used to attach panel clips (Item 2) through gypsum board, plywood, OSB, or bearing plate (Item 3, 3A, 3B, or 3C, respectively) and foamed plastic (Item 5) into liner panel (Item 8) to be No. 12-13, No. 3 Phillips drive, truss head, coated steel screws. Fastener length to penetrate liner panel min ½ in. Two fasteners per clip. Note: The panel clips may be fastened directly to the bearing plate using No.10-16 by 1 in. long self-drilling, self-tapping, pancake head No. 2 Phillips drive coated steel screws. The panel clip/bearing plate combination is to be fastened to the liner panel using two No. 12-13 truss head screws described above, inserted through guide holes in the bearing plates and into the liner panel. Min penetration ½ in.
- 6B. **Fasteners – (Screws)** – (Not Shown) – Fasteners used to attach plywood Substructure (Item 3A) through rigid insulation (Item 5) to liner panel (Item 8) to be No. 14-13, No. 3 Phillips drive truss head screws. Fastener length to penetrate liner panel min ½ in. Total of 33 fasteners per 4 by 8 ft plywood sheet to be used. Fasteners located in five rows along the 4 ft length in a 3-9-12-12-9-3 in. pattern. The two outer rows are in a 3-9-12-12-12-12-12-12-9-3 in. pattern and the three center rows are in a 2-21-24-24-21-3 in. pattern. All spacing from board edges. Fasteners used to attach panel clips (Item 2) to plywood (when plywood is fastened to liner panel as indicated above) to be No. 10-12 by 1 in. long pancake head wood screw with No. 2 Phillips drive, or No. 10-12 by 1 in. long hex-head wood screw. Two Fasteners per clip.
- 7. **Sub-Purlin** – No. 16 MSG min thick coated steel (50 ksi min yield strength). Hat section, min ¾ in. deep, 2 in. wide or Zee section, 2 in. wide, flanges 2 in. deep. Max spacing between sub-purlins to be 48 in. OC. Note: Screws used to attach sub-purlin to liner panel to be No. 12-13, No 3 Phillips drive, truss head, coated steel. Max fastener spacing to be 12 in. OC for Zee section with fasteners located in center of lower flange. For hat section, two screws, spaced 24 in. OC, located at each side of channel to be used.
- 8. **Liner Panel – (Steel Deck)** – No. 22 MSG min thick coated steel. Fabricated to various profiles (33 ksi min yield strength). Steel deck depth and profile, support spacing (max 6 ft), method of positioning (end and side laps), and fastening of deck to supports to be per deck manufacturer’s and local code requirements for uplift loading.
- 9. **Liner Panel Supports** –
 - Purlins** No. 16 MSG min thick steel (50 ksi min yield strength). Spacing to depend on design considerations for uplift loading: max 6 ft, 0 in. OC.
 - Joists** (Optional) – (Not Shown) – Open web steel joist having a min No. 16 MSG upper flange (50 ksi min yield strength) or a min 1/8 in thick upper flange (33 ksi min yield strength). Max spacing 6 ft, 0 in. OC.

Refer to General Information, Roof Deck Construction, (Roofing Materials and Systems Directory) for items not evaluated.

*Bearing the UL Classification Mark

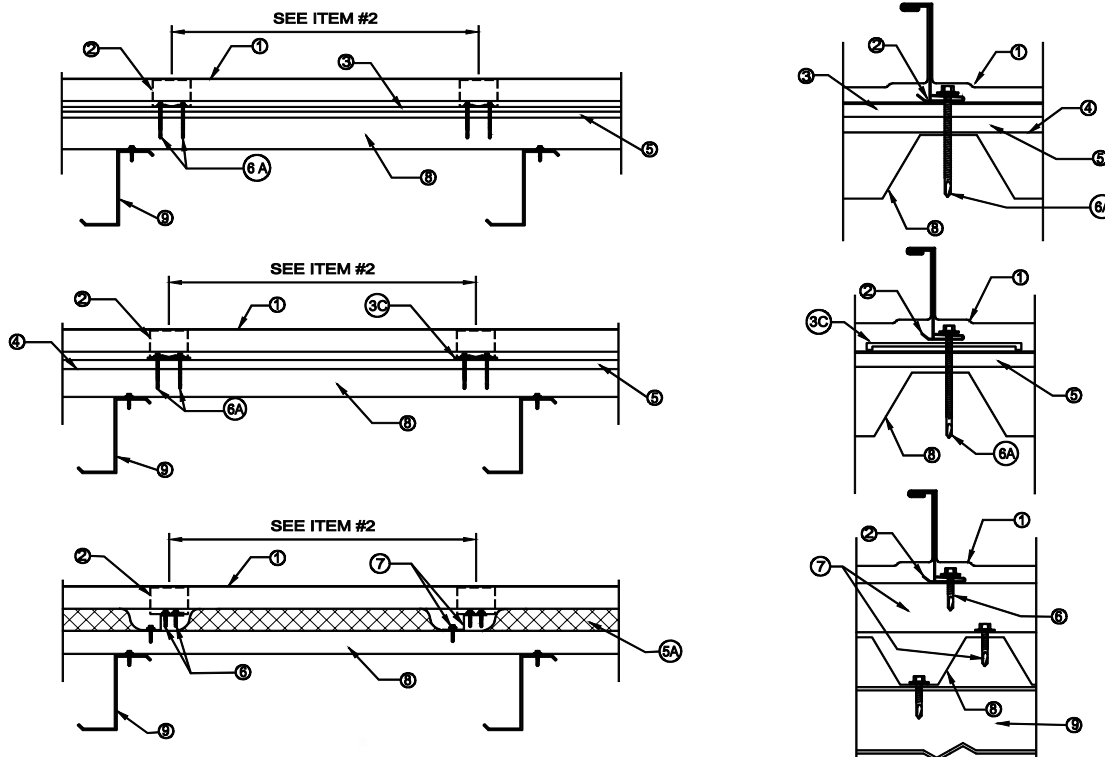

CORPORATE OFFICE
SHREVEPORT, LOUISIANA