

238T PANEL

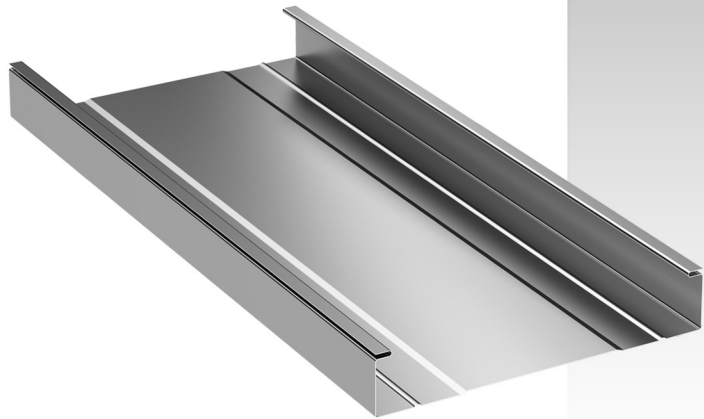

Panel/Trim/Accessories



238T PANEL

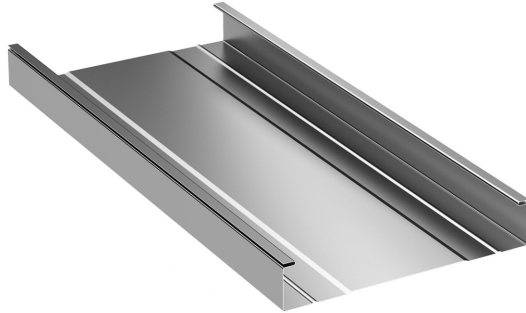

238T PANEL

238T Testing Data, Section Properties, or Load Tables

For any available Testing Data, Section Properties, or Load Tables, please visit www.mcelroymetal.com. For additional information, please contact the **McElroy Engineering Department** at 1-800-950-9082.

Details:

- Mechanically seamed
- Minimum slope 1/2:12 (subject to prior approval, 1/4:12 may be acceptable)
- Can be installed over solid deck or open framing
- Oil canning is a natural occurrence in metal panels and is not cause for panel rejection

Notes:

- Customers can rent mechanical seaming equipment directly from Developmental Industries (DI). DI is the only McElroy approved seamer supplier.
- Contents in this manual are subject to change without notice. To confirm this book is the most current copy, please visit McElroy's website at: www.mcelroymetal.com.

238T Panel Profiles

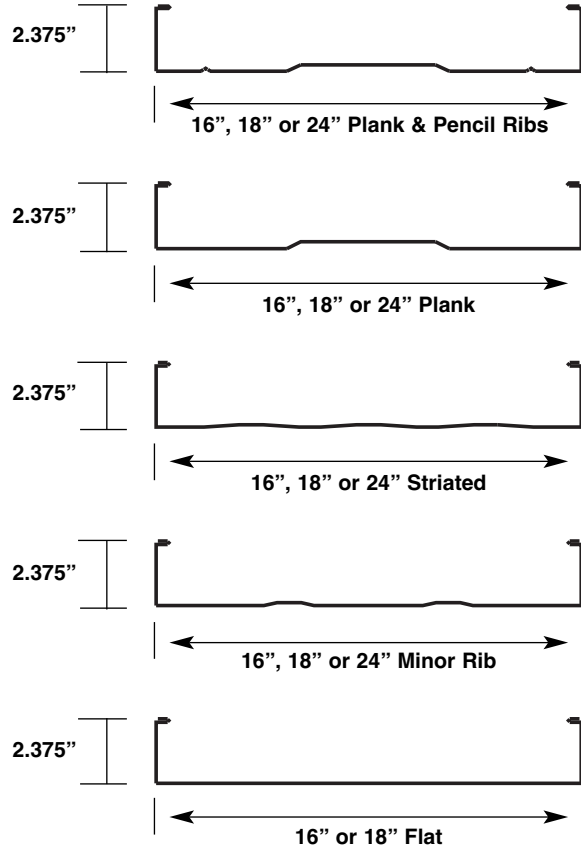

Panel Options:

- Panel width: 16", 18", 24"
(24" panel formed on-site only)
- Panel configurations: 16" & 18": flat, striated, minor ribs, plank and pencil rib (recommended)
24": striated, minor ribs, plank and pencil rib (recommended)
- Note: Flat is not an option on 24"
- Coating:
 - Kynar 500® (PVDF)
- Substrate:
 - Standard 24 GA Galvalume®
 - Optional 22 GA Galvalume
 - .032 AND .040 Aluminum
 - Optional 16 oz and 20 oz copper (Houston plant only)
- Manufacturing: factory, jobsite roll-formed, curved on-site

238T PANEL

238T Cap Installation:

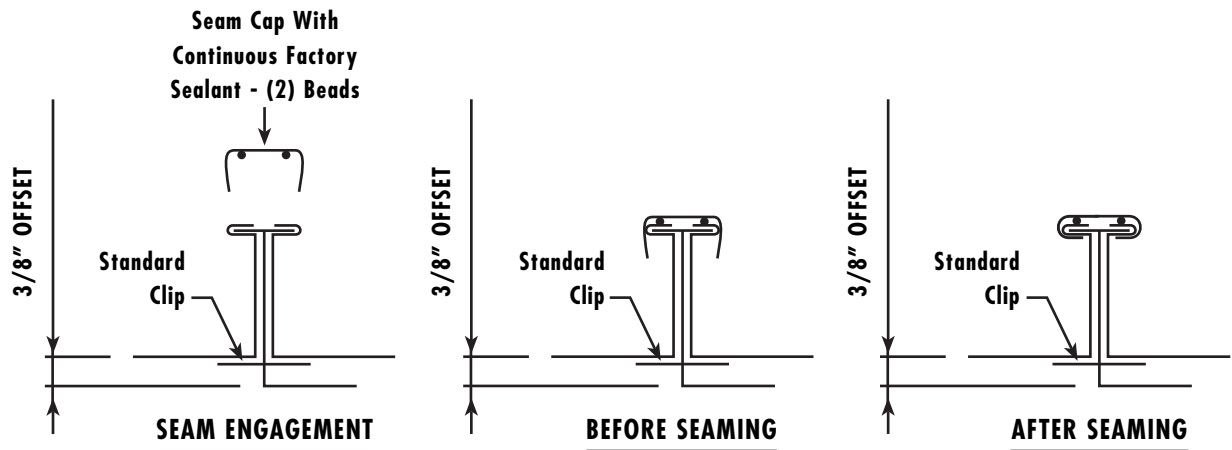

Notes:

238T Panel

TRIM

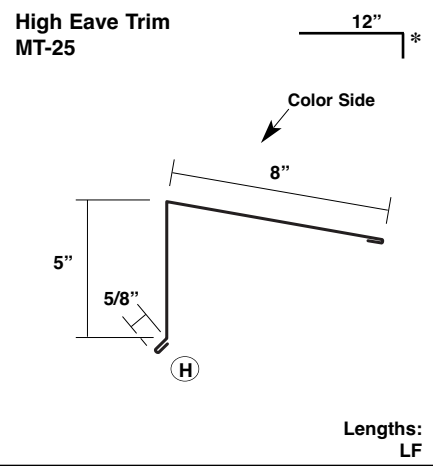
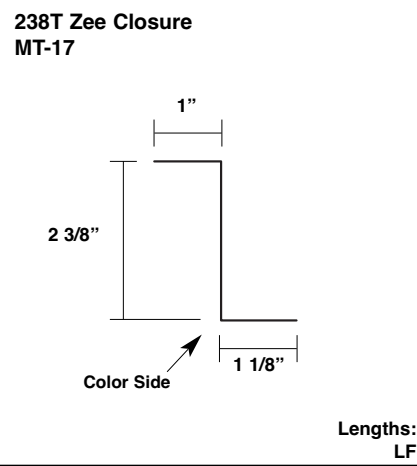
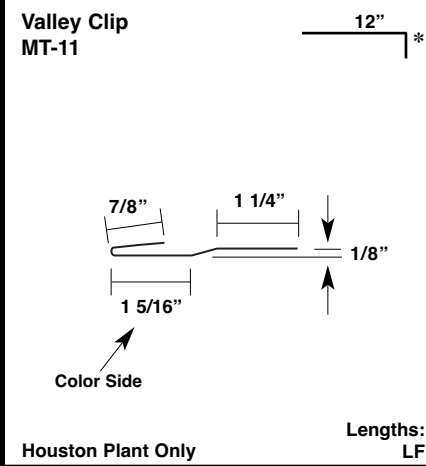
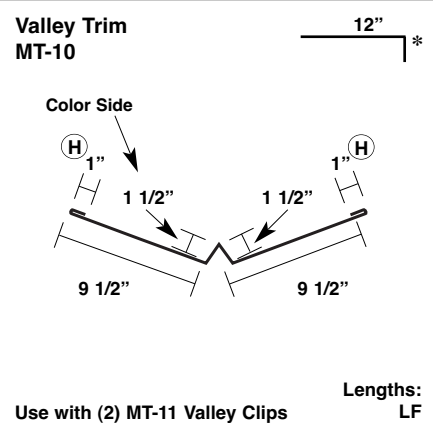
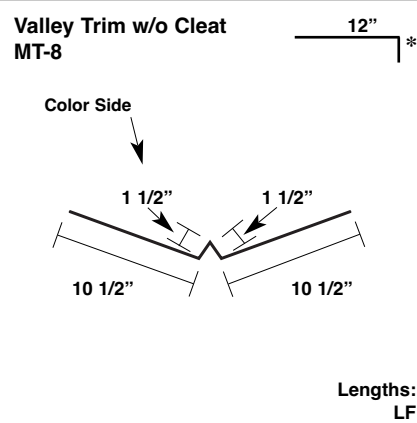
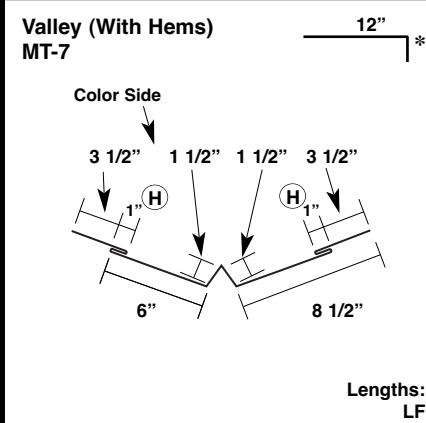
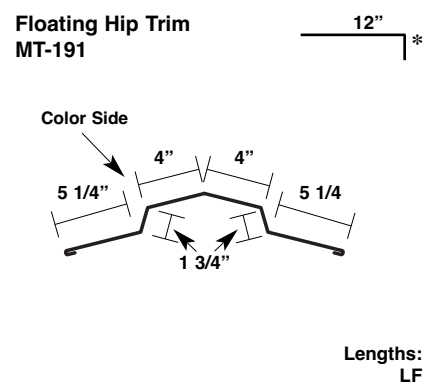
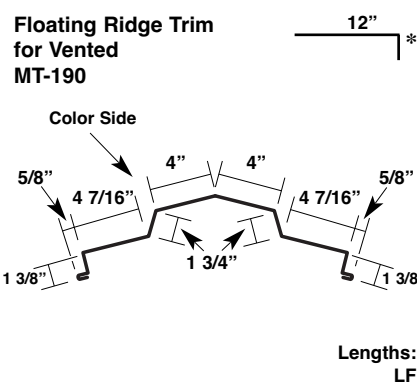
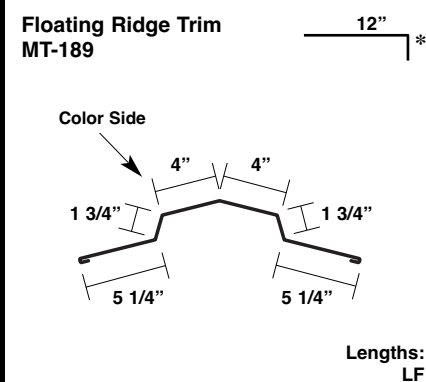
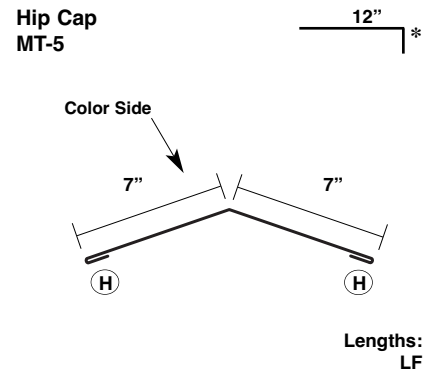
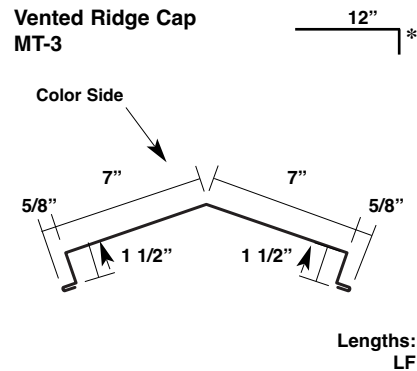
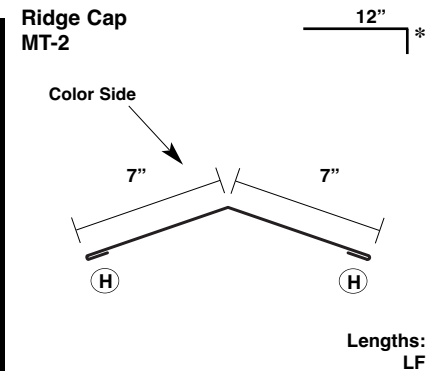

*specify roof pitch

(H) Indicates an open hem - All other hems are closed.

238T Panel

TRIM

**Standard Eave Drip Trim
MT-26**

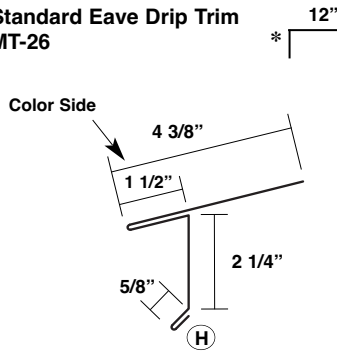

Lengths:
LF

**Alternate Eave Trim
MT-28**

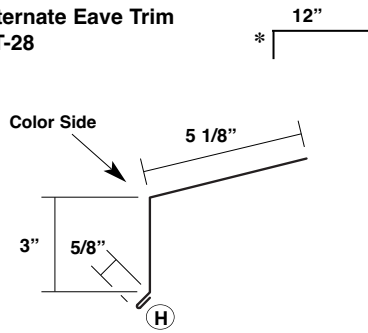

Lengths:
LF

Use with MT-38 Offset Cleat

**Alternate Eave Drip Trim
MT-29**

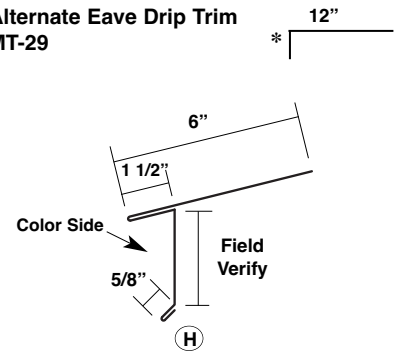

Lengths:
LF

**238T Standard Eave /
Rake Offset Flashing
MT-157**

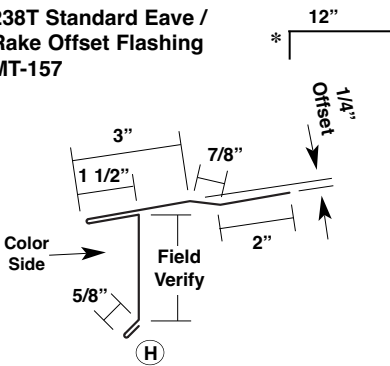

Lengths:
LF

**Standard Rake Trim
MT-31**

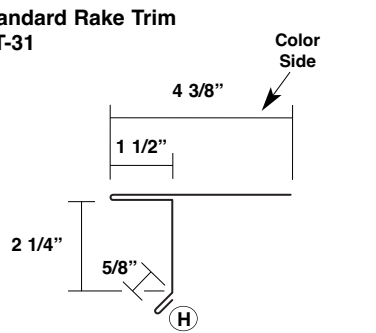

Lengths:
LF

**Standard Sidewall Trim
MT-34**

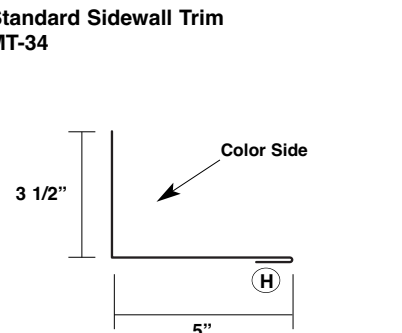

Lengths:
LF

**Standard Headwall Trim
MT-35**

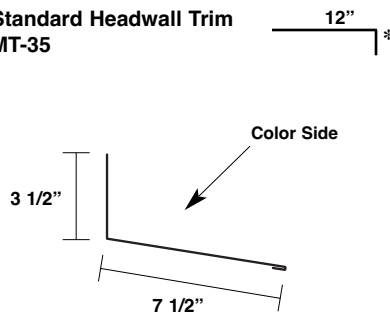

Lengths:
LF

**Standard Cleat
MT-37**

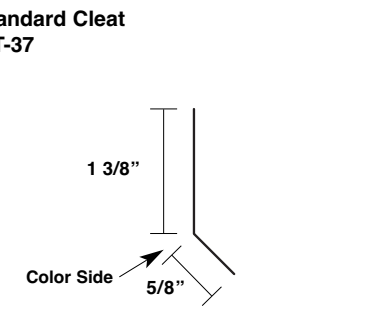

Lengths:
LF

**Standard Offset Cleat
MT-38**

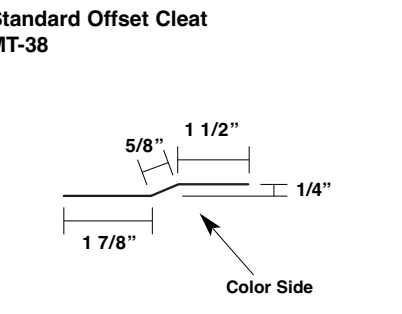

Lengths:
LF

**16 Ga 1" x 1" Back-Up Angle
Item #:226678**

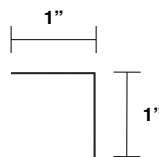

Lengths:
LF

**7" Underhung Gutter (Fixed Eave Only)
MT-63C**

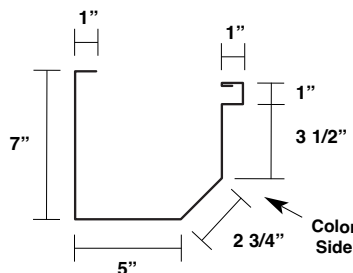

Lengths:
LF

**Standard Box Gutter
MT-61**

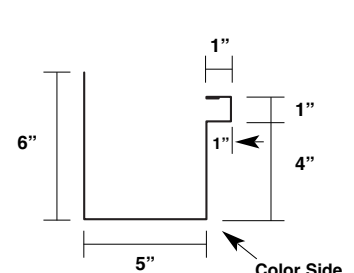

Lengths:
LF

*specify roof pitch

(H) Indicates an open hem - All other hems are closed.

238T Panel

TRIM

**Flanged Box Gutter
MT-62**

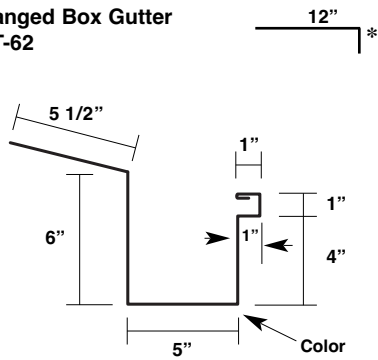

Lengths:
LF

**Gutter / Downspout Strap
MT-67**

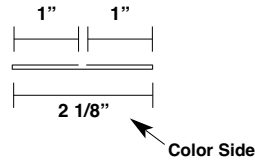

**Gutter End Cap for Standard Box
Gutter & Flanged Box Gutter
MT-68R = Right End Cap
MT-68L = Left End Cap**

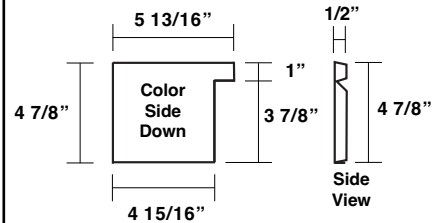

Left Hand Shown Right Hand Opposite

**Gutter End Cap for 7" Box Gutter
MT-69R = Right End Cap
MT-69L = Left End Cap**

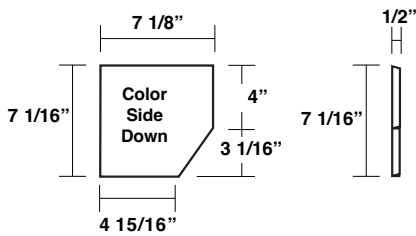

Left Hand Shown Right Hand Opposite

**Perforated "J" Channel
(Use with MT-3 Vented Ridge Cap and
MT-154 Vented Headwall)
MT-133**

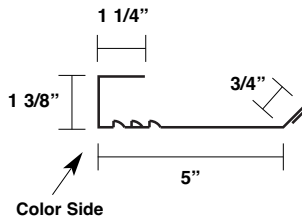

Perforations Different at
Houston Plant

Lengths:
LF

**Vented Headwall Trim
(Use with MT-133
Perforated "J" Channel)
MT-154**

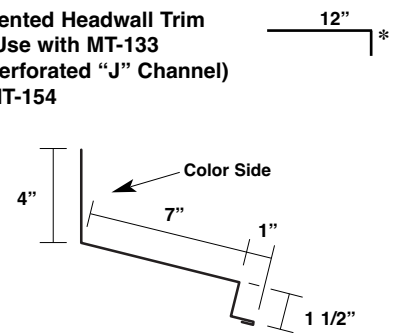

Lengths:
LF

**Rake Support Cleat
MT-156**

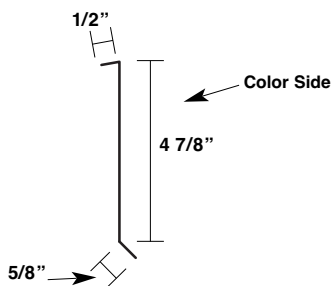

Lengths:
LF

**Rake Trim
MT-183**

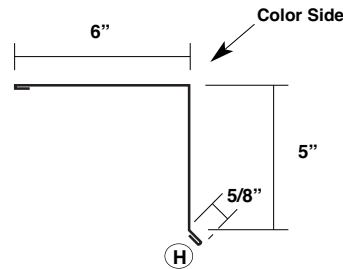

Lengths:
LF

**238T Retro Clip Eave Trim
MT-187**

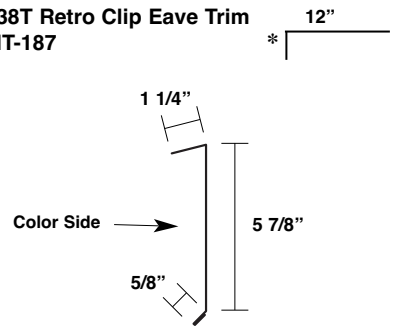

Lengths:
LF

**Floating Headwall Trim
MT-192**

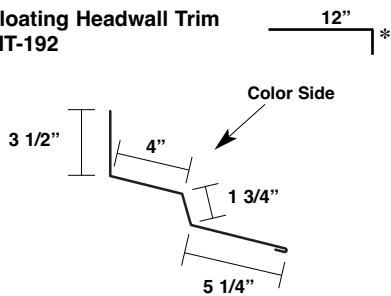

Lengths:
LF

**238T Metal Closure @ Ridge
MT-238T-CLOS**

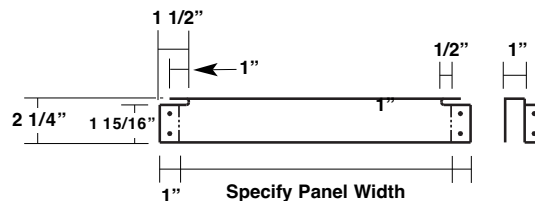

Use with Pre-Fabricated Foam Insert
Houston Plant Only

238T Panel

TRIM

238T Metal Closure @ Hip
 MT-238T-HIP

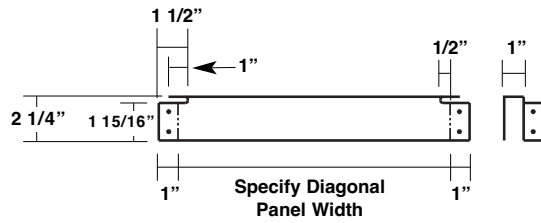

Use with Pre-Fabricated Foam Insert
 Houston Plant Only

Notes:

238T Panel

STRUCTURAL

**Rake Angle
MT-88RAGV**

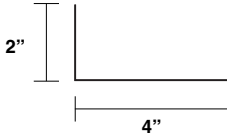

**Slotted Starter Zee
MT-SLOT-Z238**

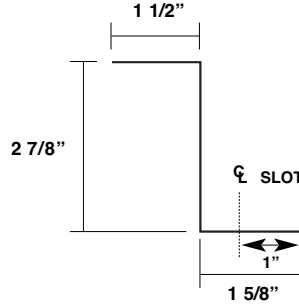

Houston Plant Only

Lengths:
LF

**238T Slotted Rake ZEE - Retrofit
MT-SLOT-Z238-RETRO**

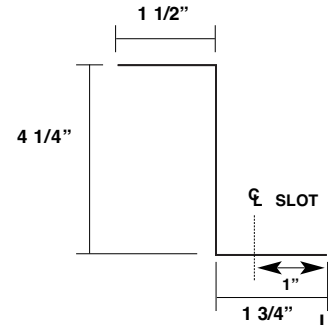

Houston Plant Only

Lengths:
LF

**Low Eave Plate
MT-185**

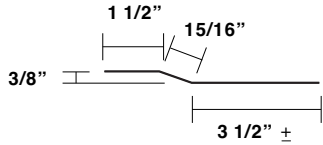

Lengths:
LF

**238T Retrofit Clip Eave Plate
MT-188**

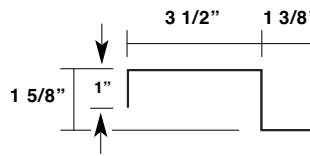

Houston Plant Only

**3/8" Offset Valley Plate
MT-200**

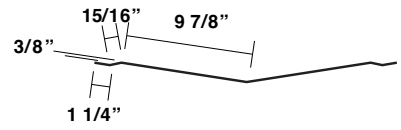

Houston Plant Only

**1 3/4" Offset Valley Plate
MT-201**

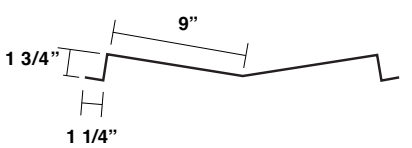

For Use With 238T Retro Clips
Houston Plant Only

**3/8" Offset Hip/Ridge Plate
MT-202**

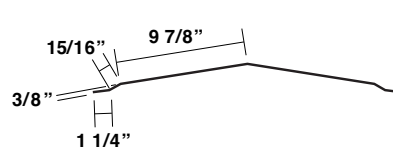

Houston Plant Only

**1 3/4" Offset Hip/Ridge
Plate
MT-203**

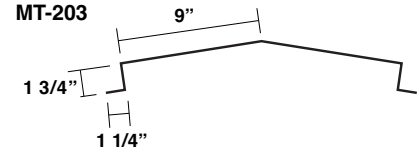

For Use With 238T Retro Clips
Houston Plant Only

**High Floating Eave Plate
MT-208**

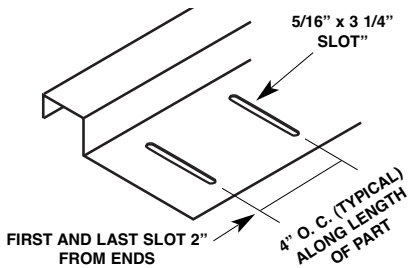

FIRST AND LAST SLOT 2" FROM ENDS

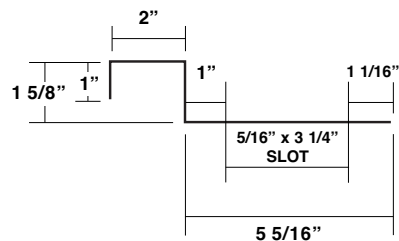

**Low Floating Eave Plate
MT-209**

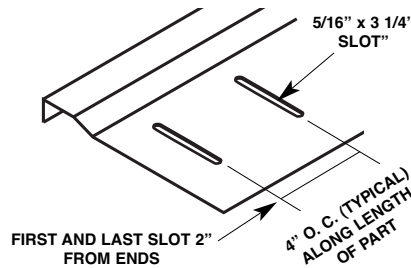

FIRST AND LAST SLOT 2" FROM ENDS

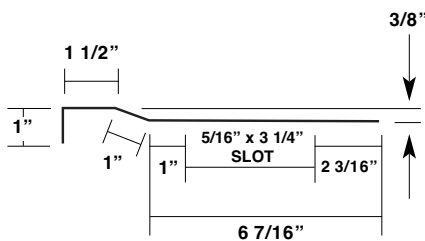

**Floating Eave
Support Plate
MT-210**

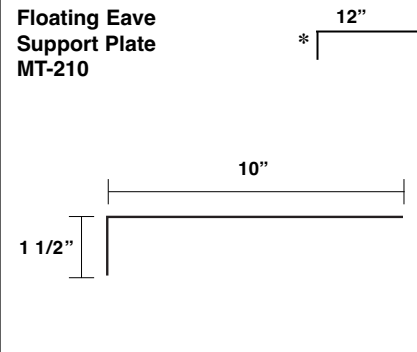

1 1/2"

238T Panel

ACCESSORIES

#10 - 12 x 1"
Type A Pancake Head
Woodgrip - Plain
Item #: 36116001

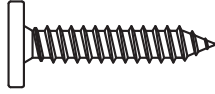

#10 - 16 x 1"
TEK2 Pancake Head
Self-Driller - Plain
Item #: 36117

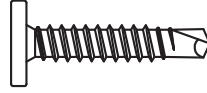

1/4 - 14 x 1 1/4"
TEK2 ZAC
(Part # varies by color.)



1/4 - 14 x 1 1/4"
Shoulder TEK2 3/8
HWH W/O Washer - Plain
Item #: 10975

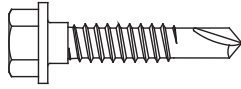

1/4 - 14 x 7/8" LAPTEK ZAC
Self Driller
(Part # varies by color)

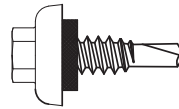

#14 x 1 1/2"
Type A W/O Washer
Item #: 94015

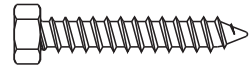

#14 - 10 x 1 1/2"
ZXL WOODBINDER
(Part # varies by color)

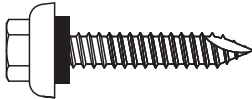

43D Pop Rivet
(Part # varies by color)

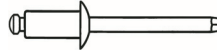

Roll Tape Sealant 3/32" x 1" x 45'
Item #: 95335

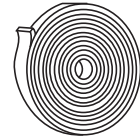

Roll Tape Sealant 3/16" x 7/8" Double
Bead Tape Sealant
Item #: 95460

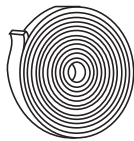

Sikalastomer Butyl Sealant
Item #: 95342



Titebond Caulk Sealant
(Part # varies by color)



Touch-Up Paint Pen
(Part # varies by color)



Standard Clip
Item #: 91821

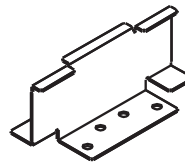

Retrofit Clip
Item #: 91822

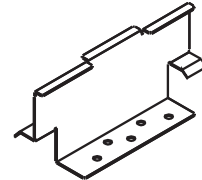

Multi-Span Clip 24 GA
Bare Item #: 21697
Painted Item #: 21677

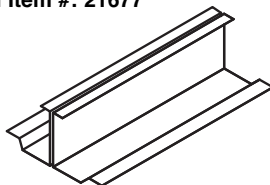

Tall Multi-Span Retrofit Clip 24 GA
Bare Item #: 22893
Painted 22883

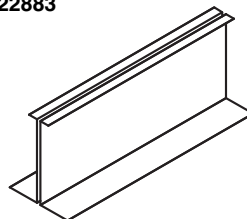

EPS Insulation for 238T Tall Clip
Recover Over R-Panel
Item #: 217420

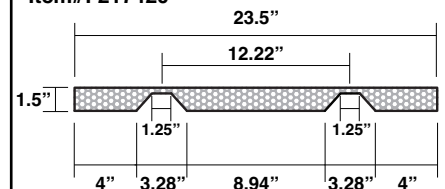

238T Panel

ACCESSORIES

1 3/8" Pedestal
Item #: 245206

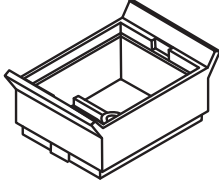

For use with Multi-Span Clip Only

238T Foam Closure
16" Item #: 91810
18" Item #: 91811
24" Item #: 94683

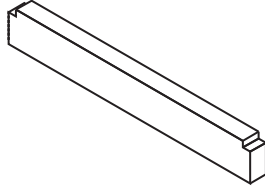

Bearing Plate 24 GA
Item #: 91818

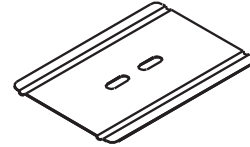

Stackable Leveling Shim
6" x 6" x 1 1/4"
Item #: 91812

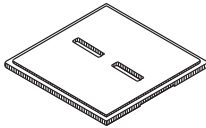

138T / 238T Hand Tongs
Item #: Long Handle 92151
Short Handle 92152

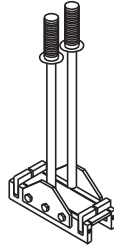

Bread Pan Tool 238T
Item #: 96023 - 24" x 2 1/4"
91890 - 18" x 2 1/4"
91891 - 16" x 2 1/4"



Notes:



☆ MANUFACTURING LOCATIONS ● SERVICE CENTERS ★ MANUFACTURING AND SERVICE CENTER



CORPORATE OFFICE
1500 HAMILTON RD.
BOSSIER CITY, LA 71111

MANUFACTURING LOCATIONS

- | | | | | |
|--------------|--------------------|------------------|----------------|-------------|
| ADELANTO, CA | ASHBURN, GA | BOSSIER CITY, LA | CLINTON, IL | DIAMOND, MO |
| HOUSTON, TX | LEWISPORT, KY | MARSHALL, MI | MAUSTON, WI | MERKEL, TX |
| | PEACHTREE CITY, GA | SUNNYVALE, TX | WINCHESTER, VA | |

MCELROY METAL
SERVICE
C E N T E R

- | | | | |
|--|--|---|--|
| 17031 Koala Road
Adelanto, CA 92301 | 5215 Leo St.
Alexandria, LA 71301 | 1007 Wilso Dr,
Baltimore, MD 21223 | 1500 Hamilton Rd.
Bossier City, LA 71111 |
| 3052 Yadkin Road
Chesapeake, VA 23323 | 9476 Meadowbrook Rd.
Clinton, IL 61727 | 3215 Highway 59
Diamond, MO 64840 | 390 N. Valley Dell Dr.
Fenton, MO 63026 |
| 409 Lovejoy Road
Ft. Walton Beach, FL 32548 | 3014 Lincoln Court
Garland, TX 75041 | 1440 Aldine Bender Road
Houston, TX 77032 | 10504 E. 59th Street
Indianapolis, IN 46236 |
| 32 Industrial Circle
Lancaster, PA 17601 | 9435 US Hwy. 60 W.
Lewisport, KY 42351 | 1020 Veterans Street
Mauston, WI 53948 | 5123 Terminal Dr.
McFarland, WI 53558 |
| 514 Cave Road
Nashville, TN 37210 | 8304 Hwy. 70 E.
North Little Rock, AR 72117 | 613 North Bierdeman Rd.
Pearl, MS 39208 | 8511 Industrial Drive
Pearland, TX 77584 |
| 2755 Hwy 60
Pendergrass, GA 30567 | 7450 Tower Street
Richland Hills, TX 76118 | 8200 Berry Ave. Suite 100
Sacramento, CA 95828 | 1365 Dean Forest Rd.
Savannah, GA 31405 |
| 7355 Oakley Industrial Blvd.
Union City, GA 30291 | 1144 Silstar Rd.
West Columbia, SC 29170 | 325 McGhee Rd.
Winchester, VA 22603 | |

Website: www.mcelroymetal.com • E-mail: info@mcelroymetal.com